

SX/WN-V1  
20 AMP Single Receptacle w/ Standard Weatherproof  
Cover-120 Volt

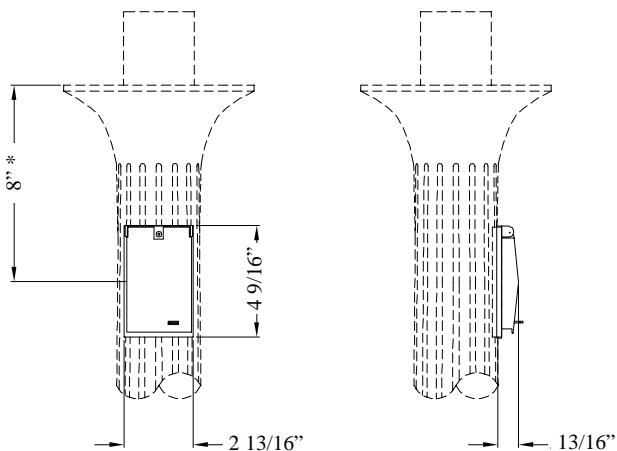

DX/WN-V1  
Duplex Receptacle w/ Standard Weatherproof Cover-120 Volt

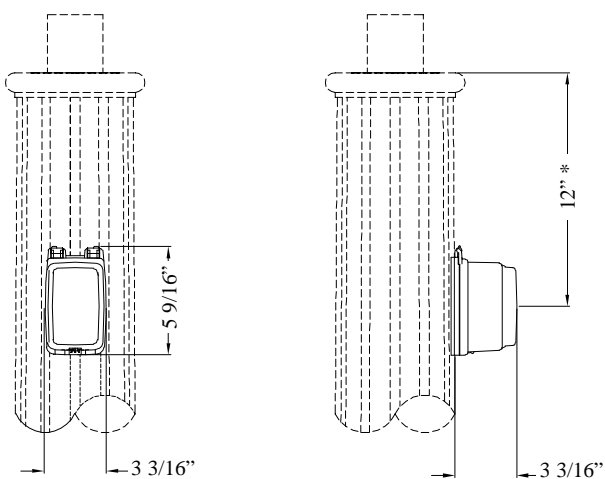

GF/WI-V1  
GFI Receptacle w/ Weatherproof In Use Cover-120 Volt

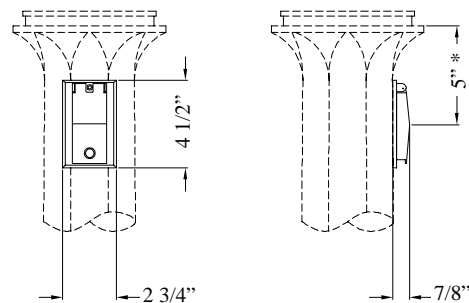

GF/WN-V1  
GFI Receptacle w/ Standard Weatherproof Cover-120 Volt

\* May vary depending upon project criteria



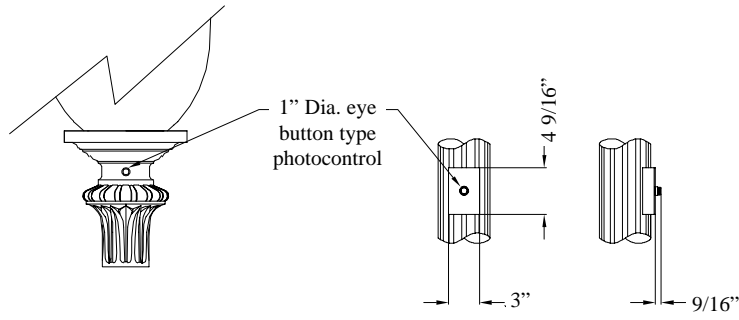

Post Mounted Button  
Type Photo Control.

Post Mounted Button  
Type Photo Control.

**BT-V1**  
Button Type Photo Control - 120 Volt

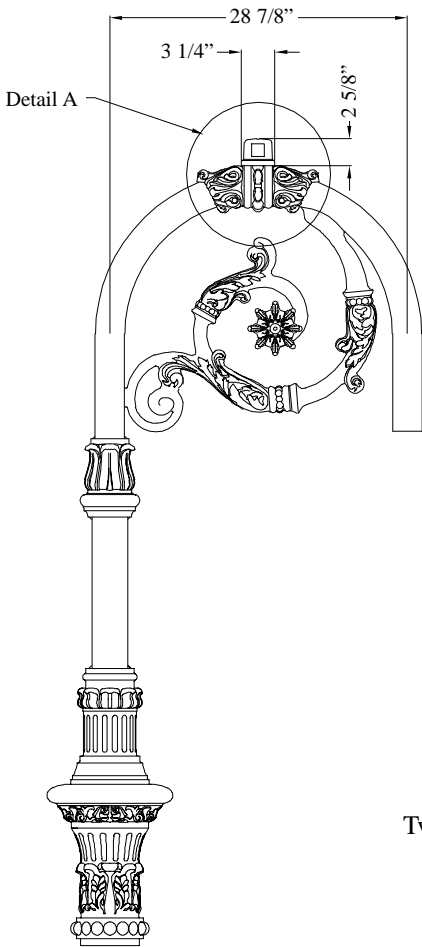

**TT/TR-V1**  
Twist Lock Photo Control w/Twist Lock  
Receptacle - 120 Volt

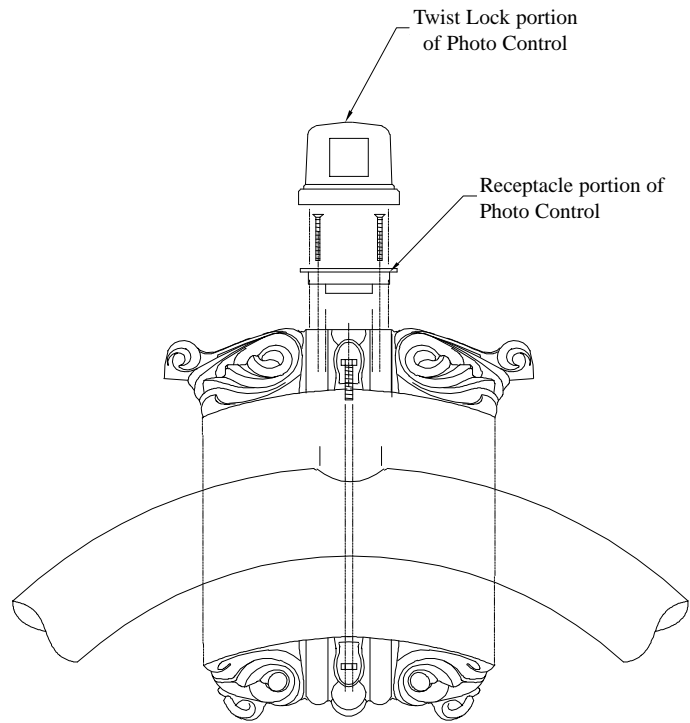

Detail A



# Banner Arms

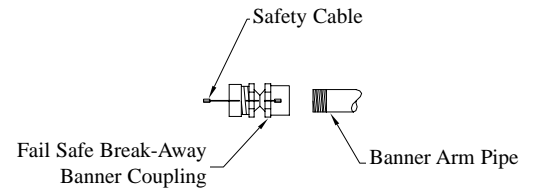
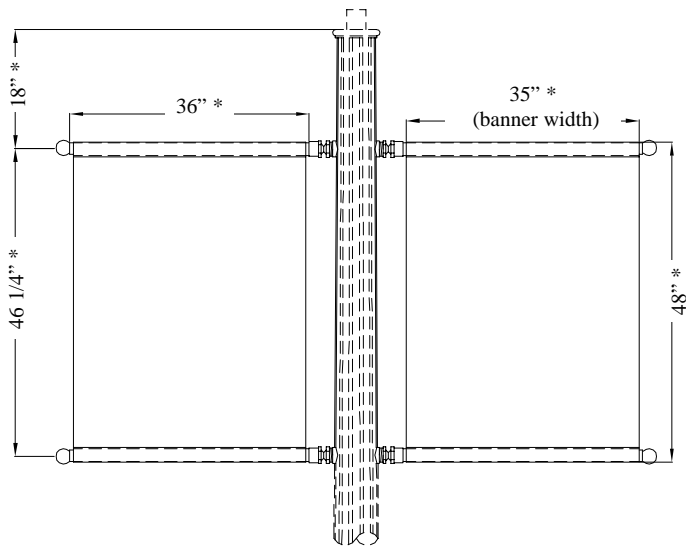

**Detail of Breakaway Coupling**

**4 AARB/BA35-SC8-FO2-RM**  
 4 Aluminum Arms Banner Arms / Breakaway 35"  
 Banner Width- Schedule 80 pipe - 2" Ball finial -  
 Removable

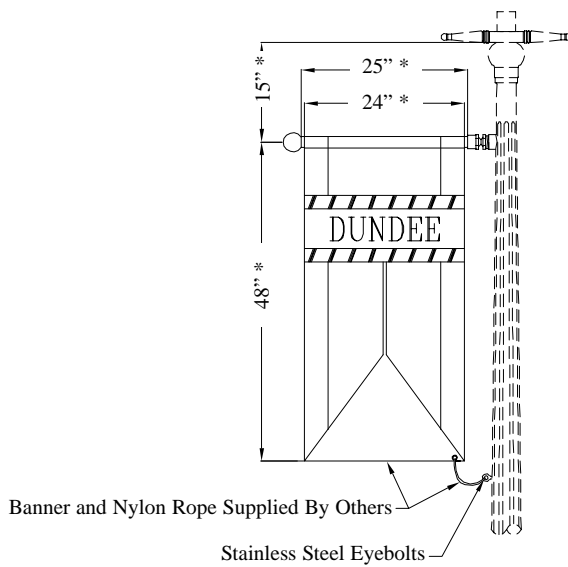

**1 AARB/BA24-SC8-EB-FO2-RM**  
 1 Aluminum Arm Banner Arm / Breakaway 24"  
 Banner Width - Schedule 80 pipe - Eyebolt -  
 2" Ball finial - Removable

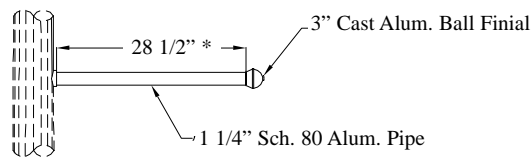

**1AARB28.5-SC8-FO3-RM**  
 1 Aluminum Arm Banner Arm 28" Banner Width - Schedule  
 80 pipe - 3" Ball Finial - Removable

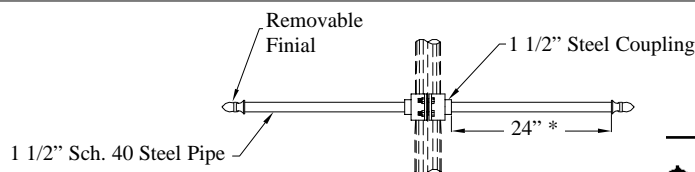

**2 SARBN/CM24-SC4-WRC-RM**  
 2 Steel Arms Banner Arms / Clamp on 24"  
 Banner Width - Schedule 40 pipe - Worcester  
 Finial - Removable

\* May vary depending upon project criteria



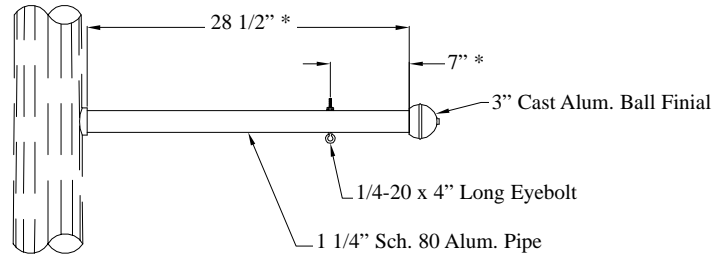

1 AARBK28.5-SC8-EB-FO3  
 1 Aluminum Arm Bracket 28 1/2" Arm  
 length - Schedule 80 Pipe - Eyebolt - 3"  
 Ball Finial

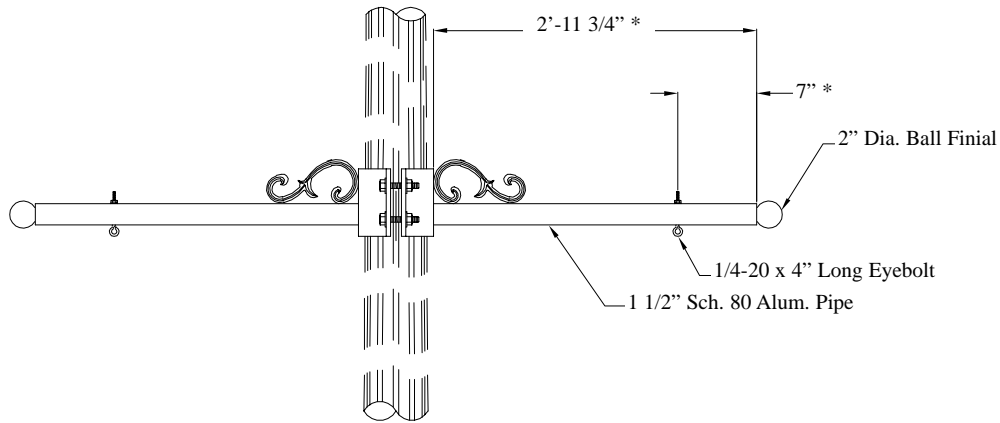

2 AARBK/CM35.75-SC8-EB-FO2  
 2 Aluminum Arm Bracket / Clamp Style 35 3/4"  
 Arm Length-Schedule 80 Pipe - Eyebolt - 2" Ball  
 Finial

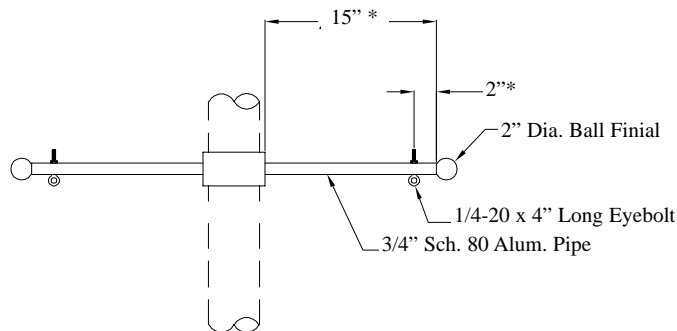

2 AARBK15-SC8-EB-FO2  
 2 Aluminum Arm Bracket 15" Arm Length - Schedule 80  
 Pipe- Eyebolt - 2" Ball Finial



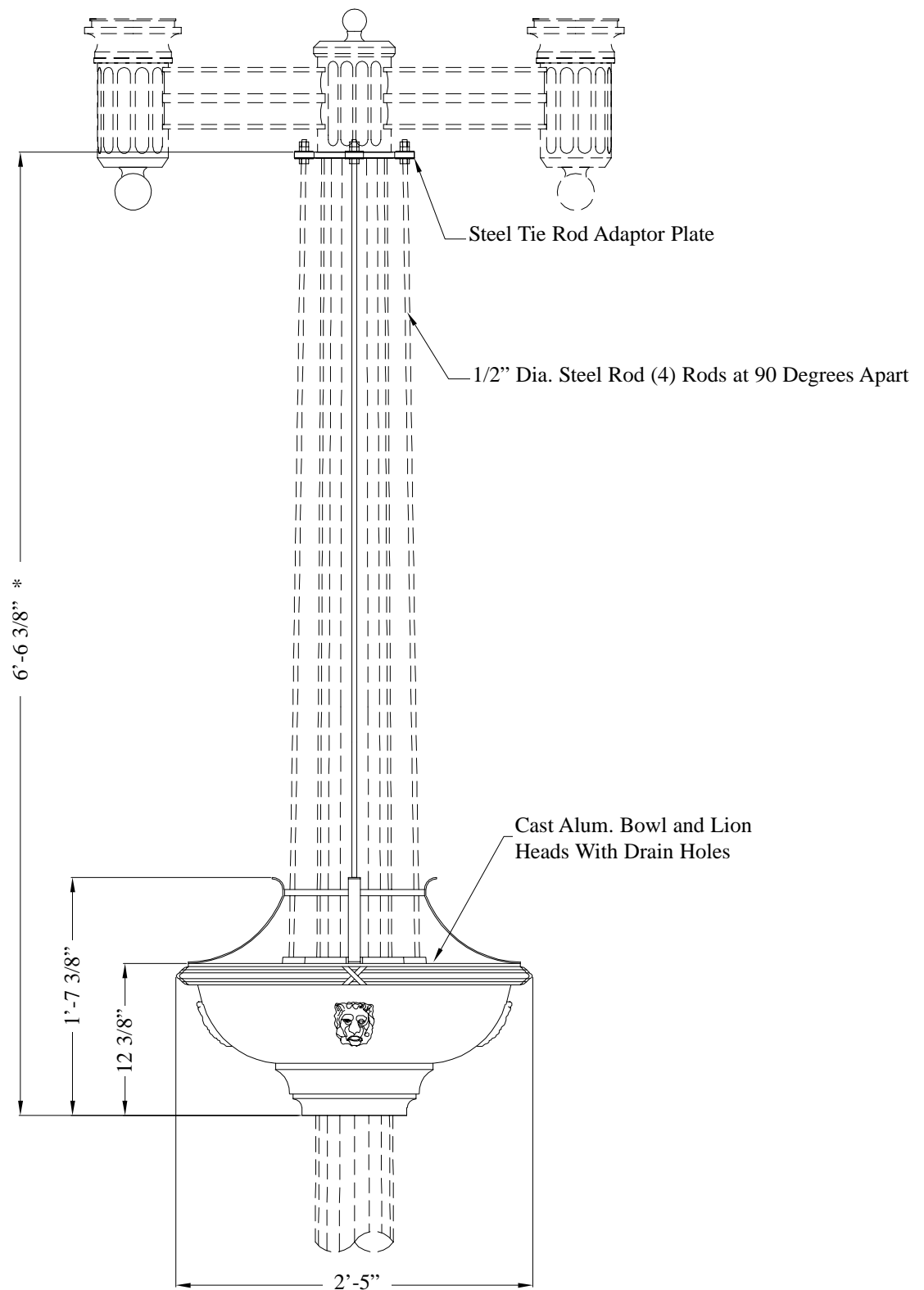

1 ABKALN  
1 Aluminum Bracket Allentown Bowl Assembly



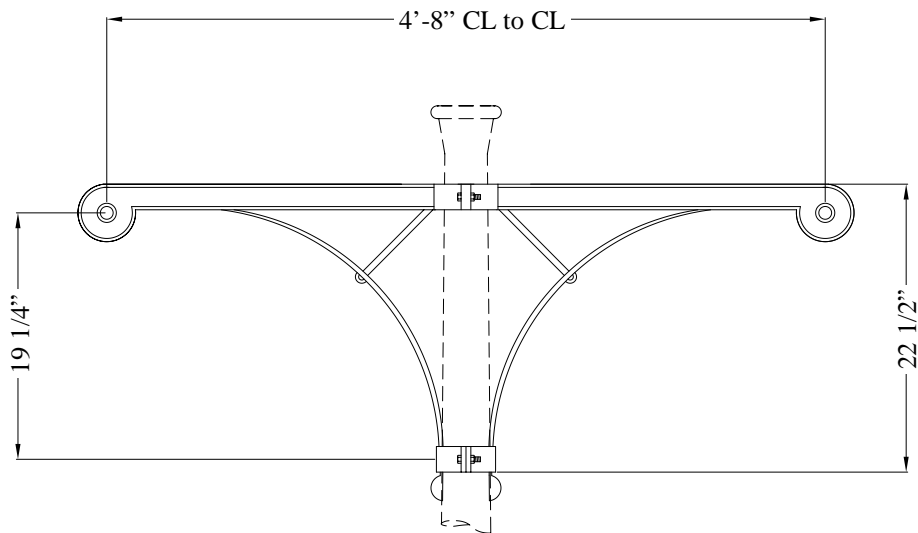

2 AARWSH -BK-CM  
2 Cast Aluminum Arm Washington - Flower Pot  
Bracket - Clamp Mount

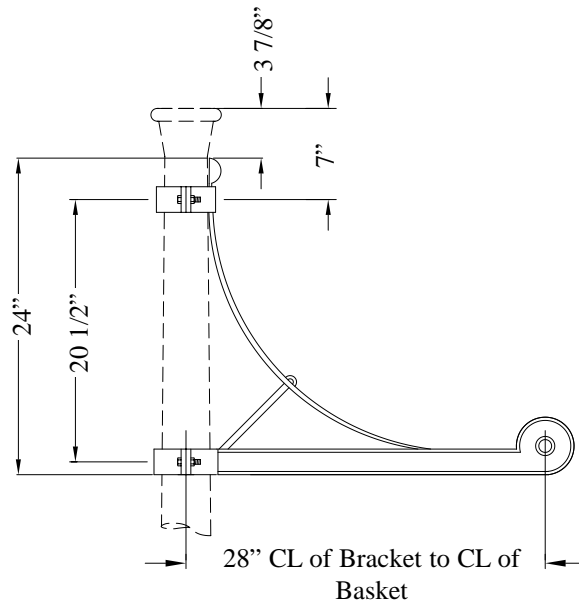

1 AARWSH -BK-CM-CB  
1 Cast Aluminum Arm Washington - Flower Pot  
Bracket - Clamp Mount - Classic Black Finish



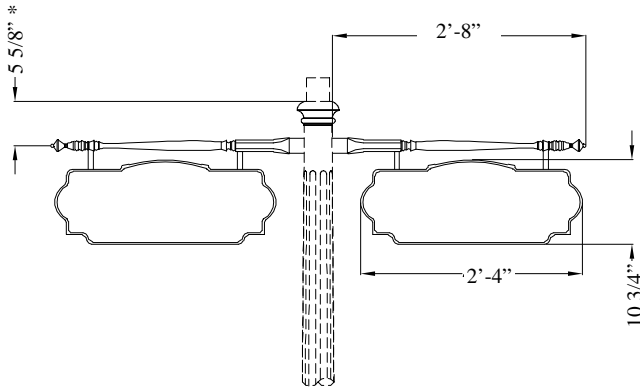

2 AARWNC-SS32  
2 Cast Aluminum Arms Winchester  
Street Signs 32" Arm Width

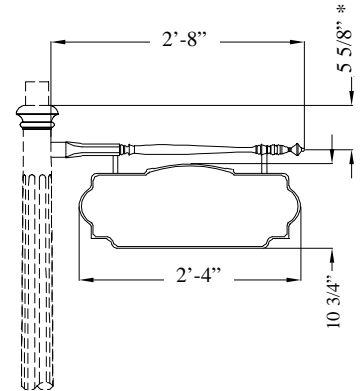

1 AARWNC-SS32  
1 Cast Aluminum Arms Winchester  
Street Signs 32" Arm Width

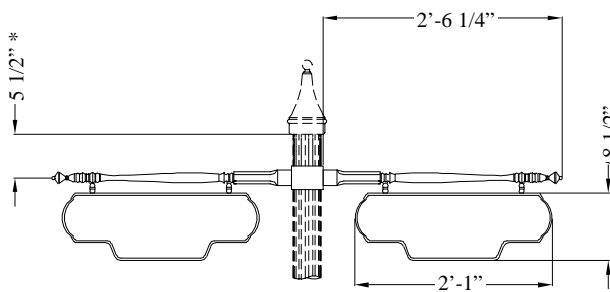

2 AARNGR-SS30  
2 Cast Aluminum Arms Niagara Street  
Signs 30" Arm Width

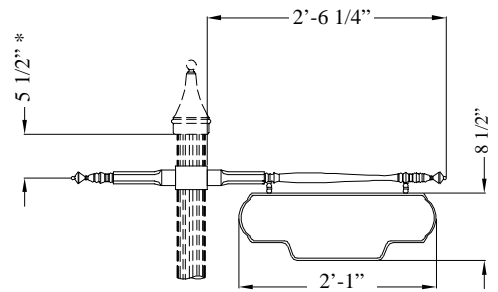

1 AARNGR-SS30  
1 Cast Aluminum Arms Niagara Street  
Signs 30" Arm Width

\* May vary depending upon project criteria



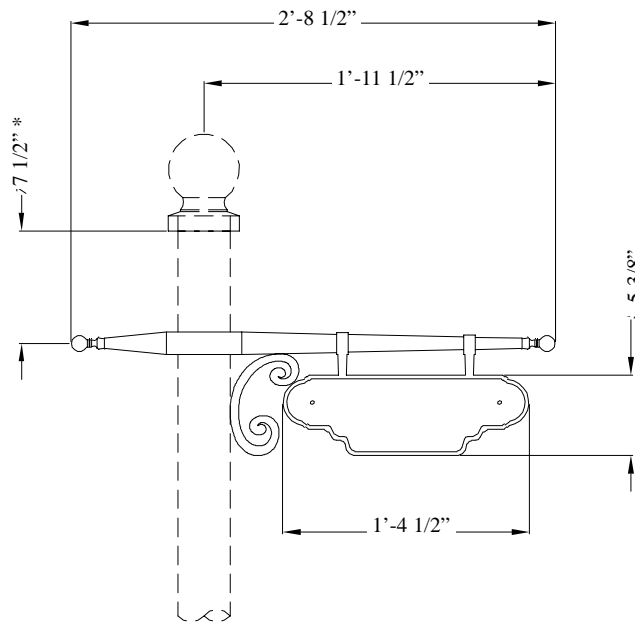

1 AARHRV- SS23  
1 Cast Aluminum Arm Harvard - Street  
Sign 23"

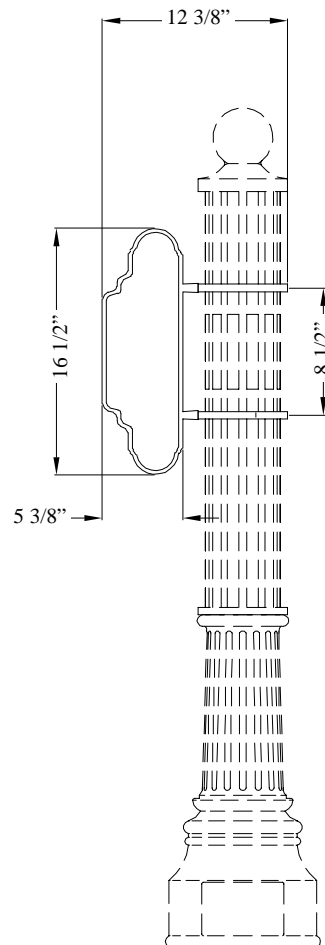

1 AARGTT - SS16.5  
1 Cast Aluminum Arm Gettysburg -  
Street Sign 16.5"

\* May vary depending upon project criteria



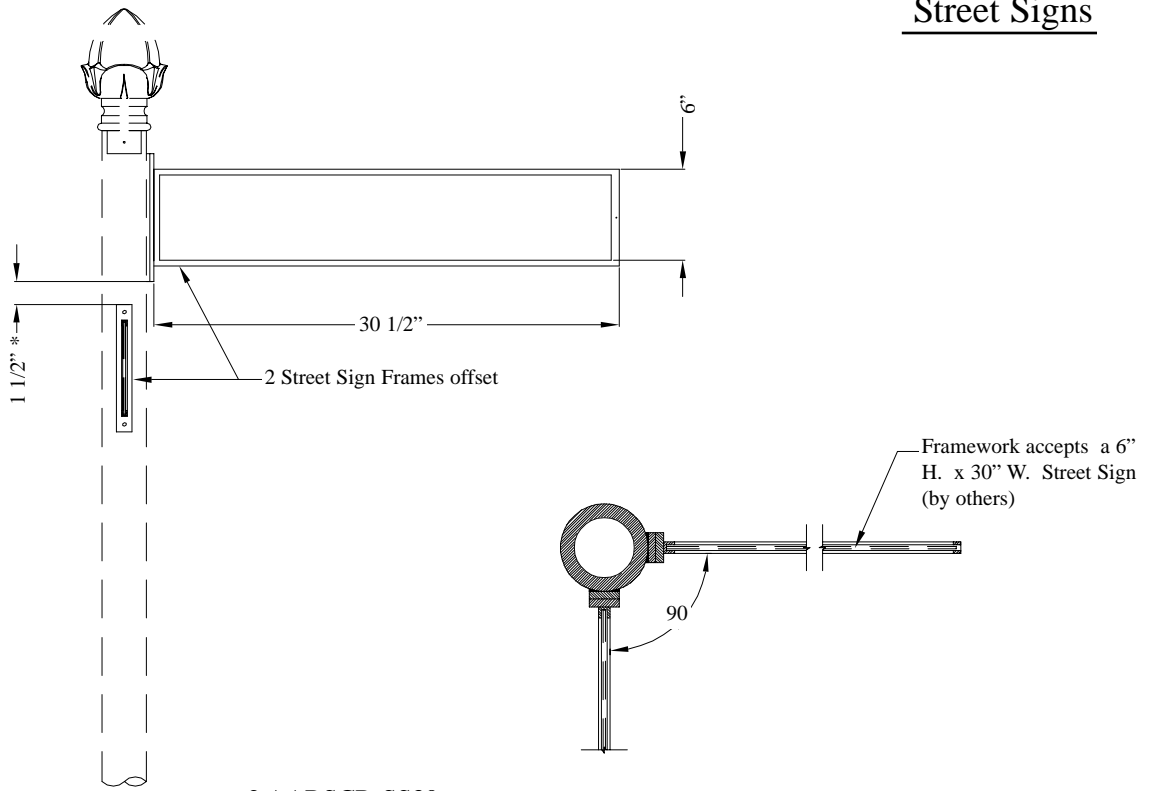

2 AARSCR-SS30  
2 Aluminum Arms Scarsdale -  
Street Signs 30.5"

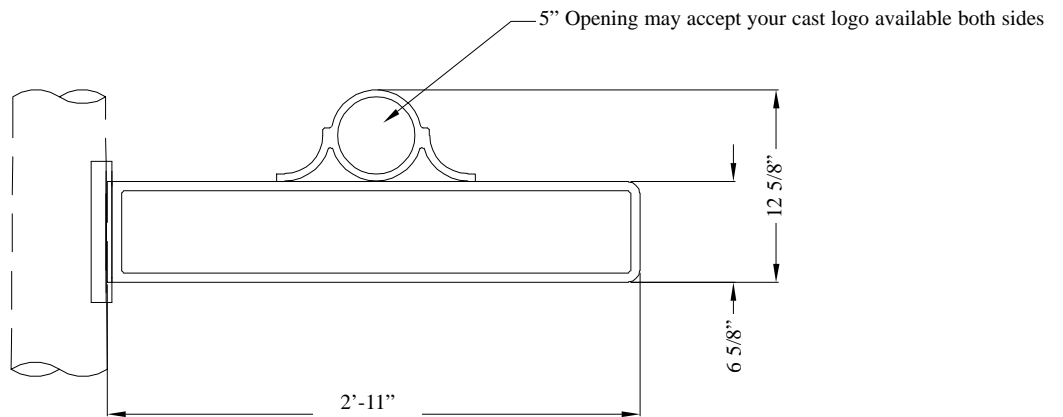
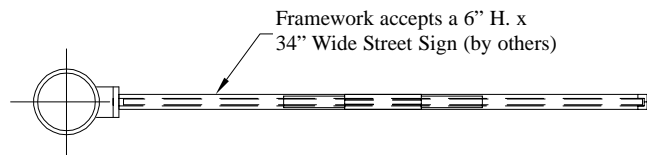

1 AARWTY-SS35  
1 Aluminum Arm Westerly - Street  
Sign 35"

\* May vary depending upon project criteria



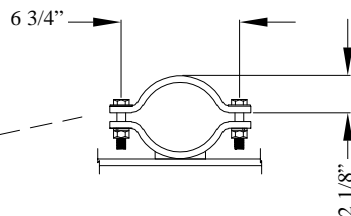
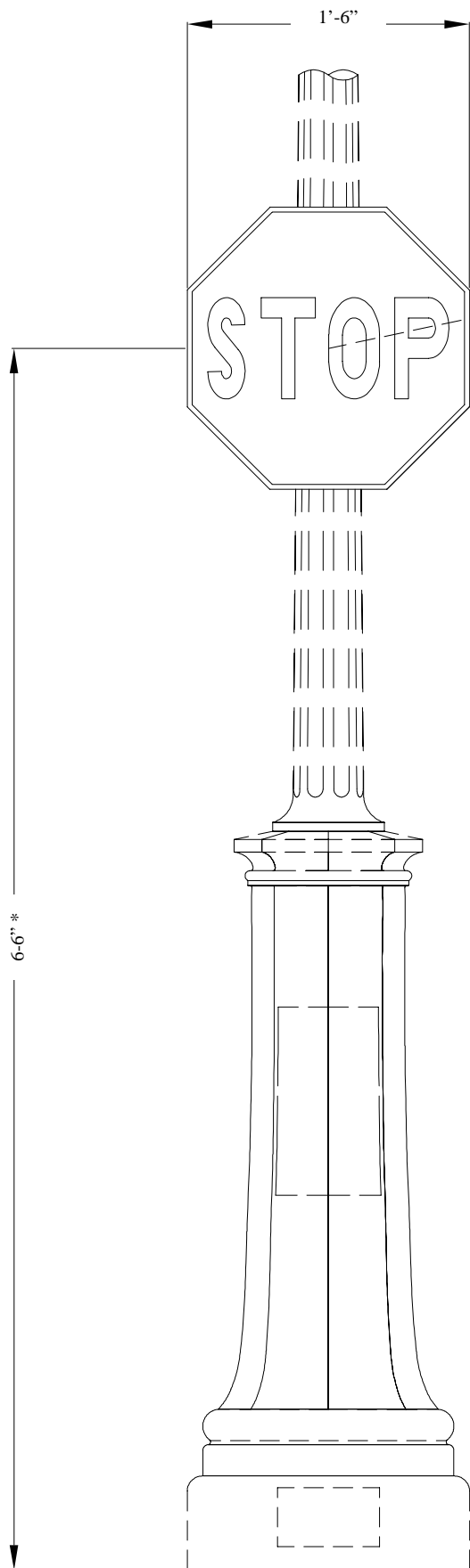

1 AARSTP- SS- CM  
1 Aluminum Arm Stop Sign - Street Sign -  
Clamp Mount

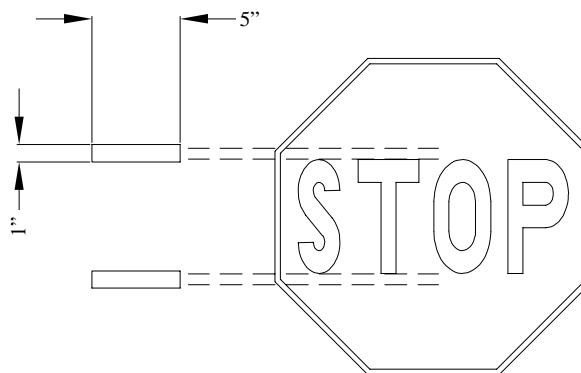

1 AARSTP- SS- SD - CW  
1 Aluminum Arm Stop Sign - Street Sign -  
Side Mount - Custom Wet Finish

\* May vary depending upon project criteria



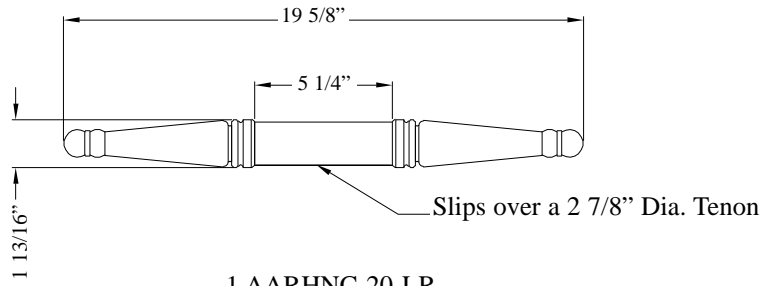

1 AARHNC-20-LR  
1 Cast Aluminum Arm Hancock - 19 5/8"  
- Ladder Rest

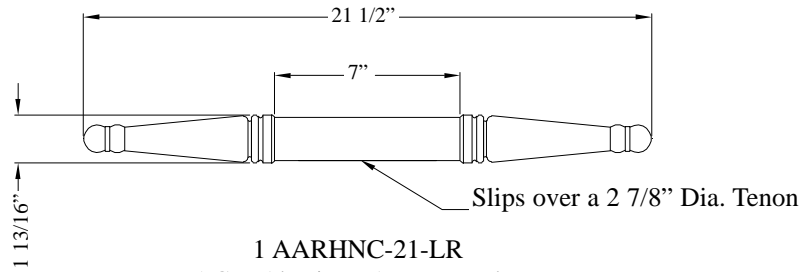

1 AARHNC-21-LR  
1 Cast Aluminum Arm Hancock -  
21 1/2" - Ladder Rest

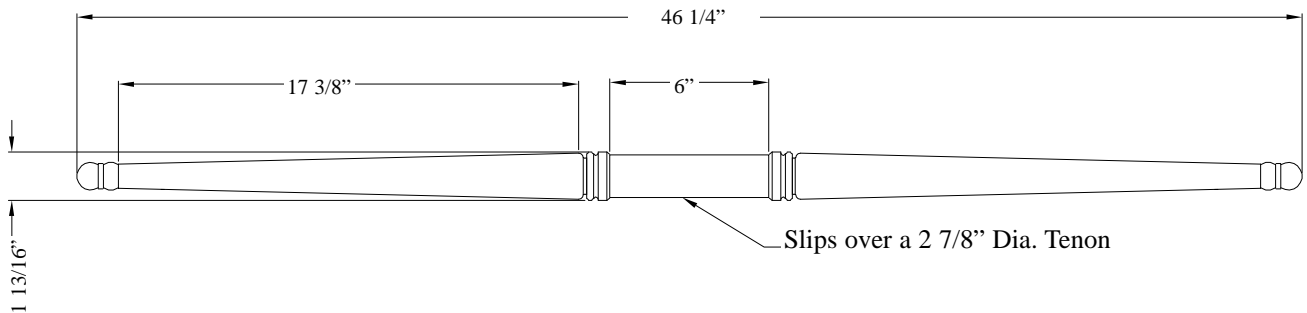

1 AARHNC-46-LR  
1 Cast Aluminum Arm Hancock - 46 1/4"  
Ladder Rest

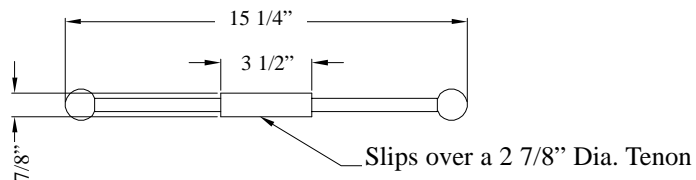

1 AARHRV-15-LR  
1 Cast Aluminum Arm  
Harvard - 15 1/4" - Ladder  
Rest



# Ladder Rest

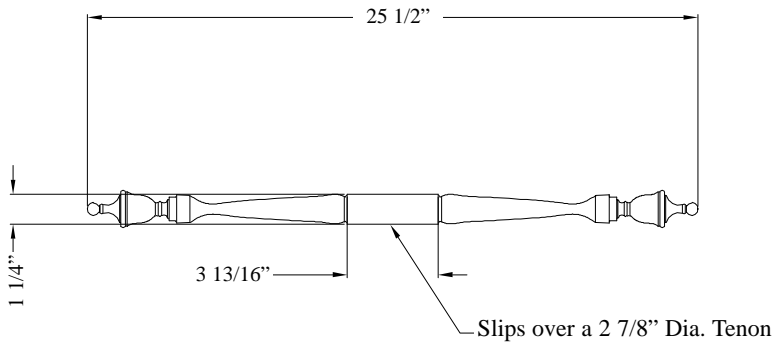

1 AARMNC-25-LR  
1 Cast Aluminum Arm Manchester -  
25 1/2" - Ladder Rest

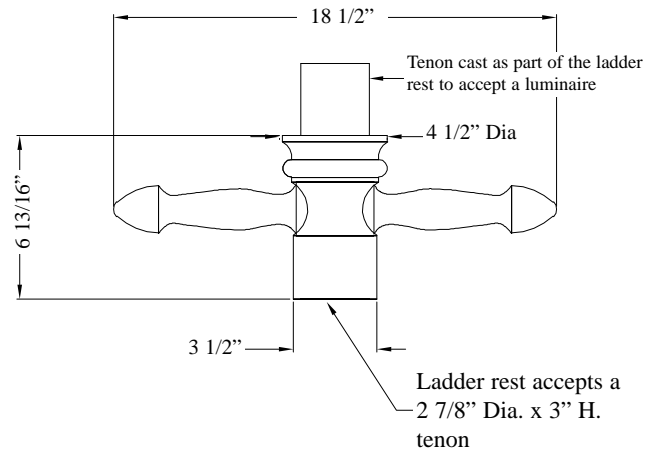

1 AARNBP-18-LR  
1 Cast Aluminum Arm Newburyport -  
18 1/2" - Ladder Rest

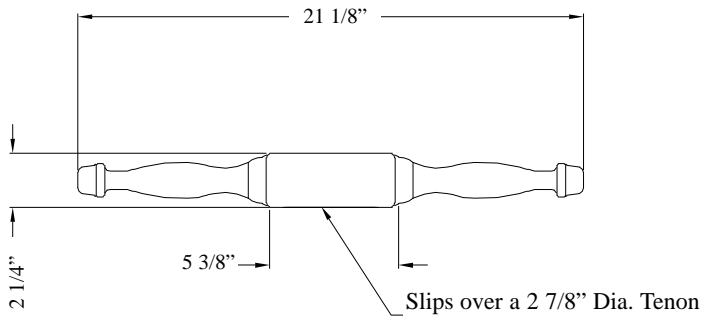

1 AARPRC-21-LR  
1 Cast Aluminum Arm Princeton - 21 1/8" -  
Ladder Rest

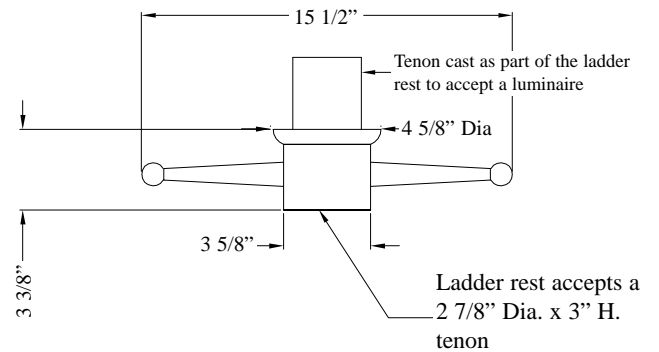

1 AARIDT-15-LR  
1 Cast Aluminum Arm Independence -  
15 1/2" - Ladder Rest



# Adaptors / Capitals

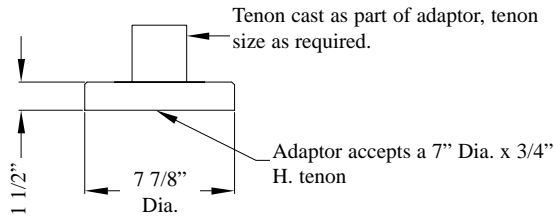

**ALAGRG**  
Cast Aluminum Luminaire  
Adaptor Georgetown

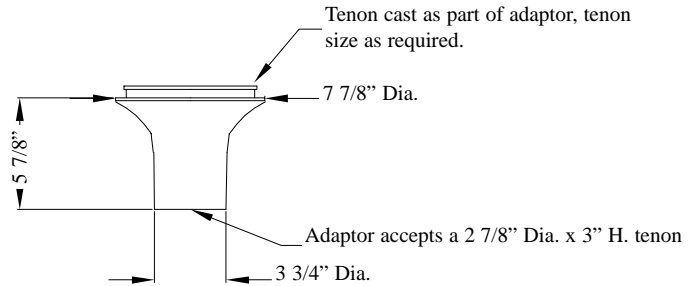

**ALAVLL**  
Cast Aluminum Luminaire  
Adaptor Villa

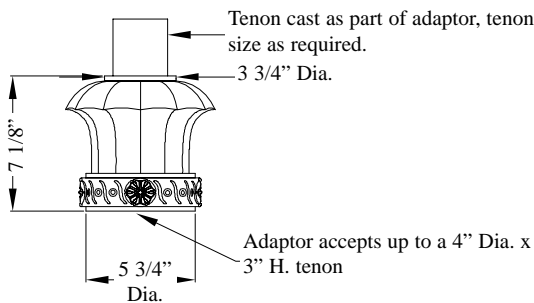

**ALAPAV**  
Aluminum Luminaire Adaptor  
Pavilion

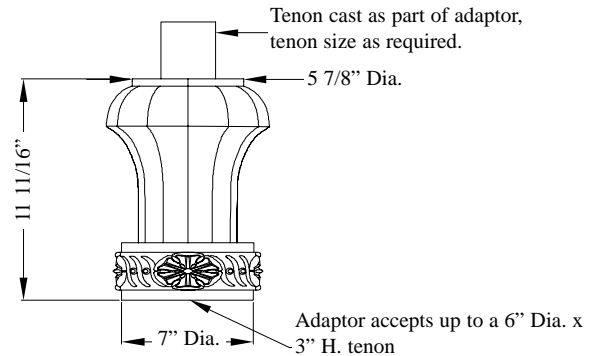

**ALAPTL**  
Cast Aluminum Luminaire Adaptor  
Port Liberté

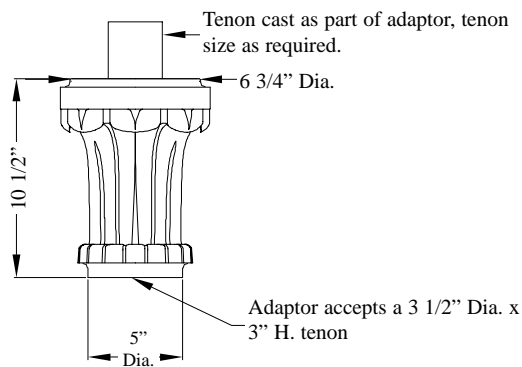

**ALAMDR**  
Cast Aluminum Luminaire Adaptor  
Madrid

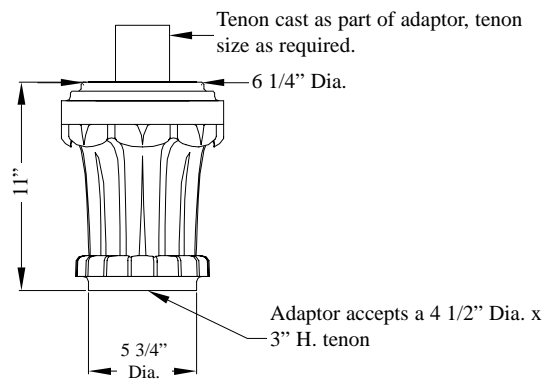

**ALAMDS**  
Cast Aluminum Luminaire Adaptor  
Madison



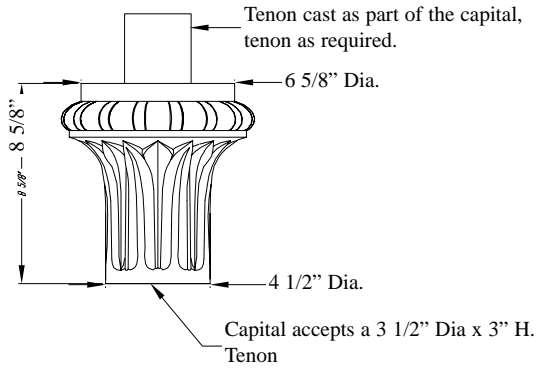

**ACTWSH**  
Cast Aluminum Capital Washington

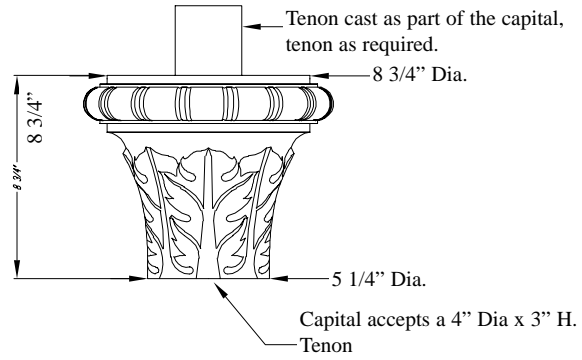

**ACTNWF**  
Cast Aluminum Capital New Frontier

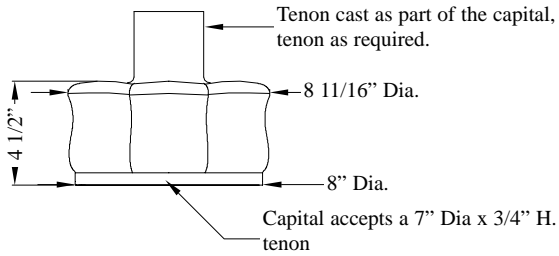

**ACTARM**  
Cast Aluminum Capital Armory Square

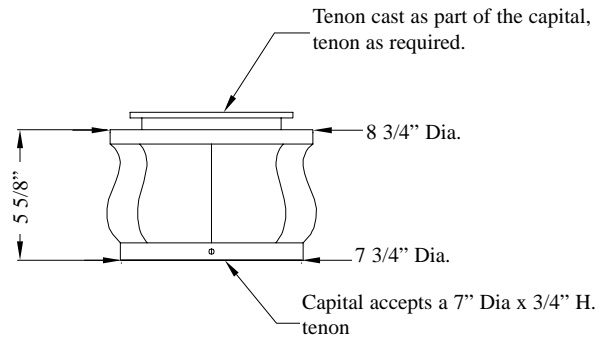

**ACTTRB**  
Cast Aluminum Capital Tarboro

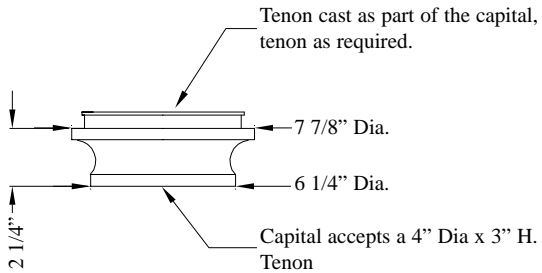

**ACTALN**  
Cast Aluminum Capital Allentown

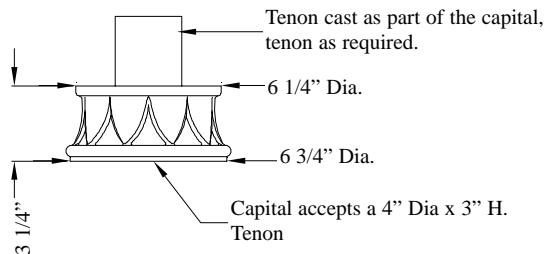

**ACTLKW**  
Cast Aluminum Capital Lakewood



## Adaptors / Capitals

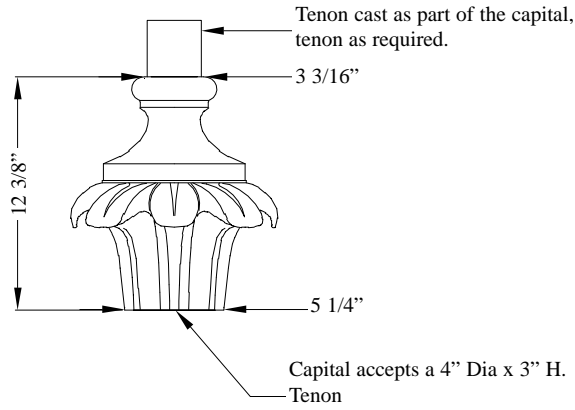

**ACTOLD**  
Cast Aluminum Capital Old Town

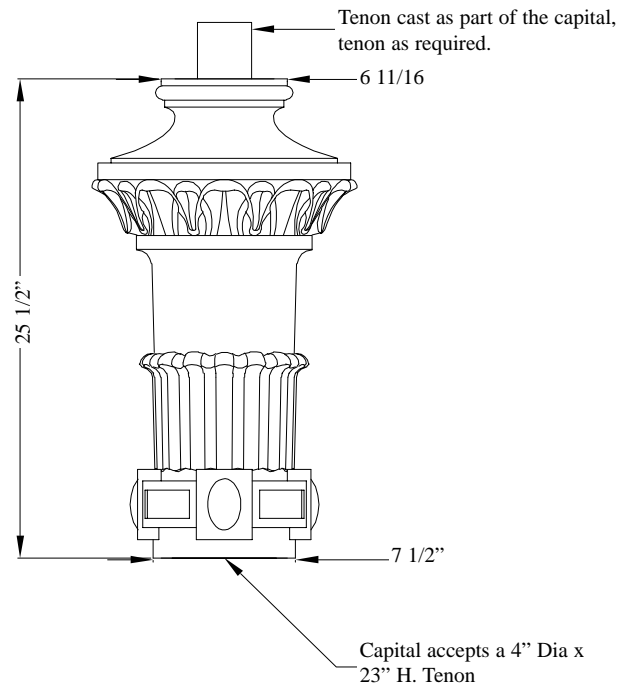

**ACTBRT**  
Cast Aluminum Capital Brentwood

## Flag Holders

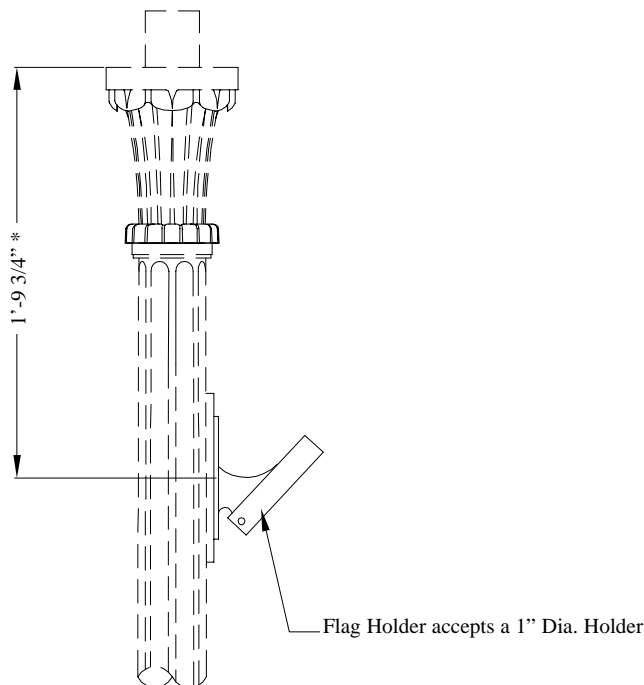

**AARRDN-FH**  
Aluminum Arm Radnor - Flag Holder

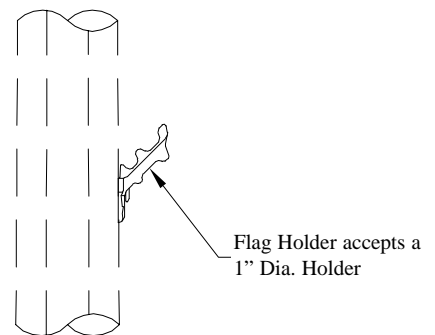

**AARWSH-FH**  
Aluminum Arm Washington - Flag Holder

\* May vary depending upon project criteria



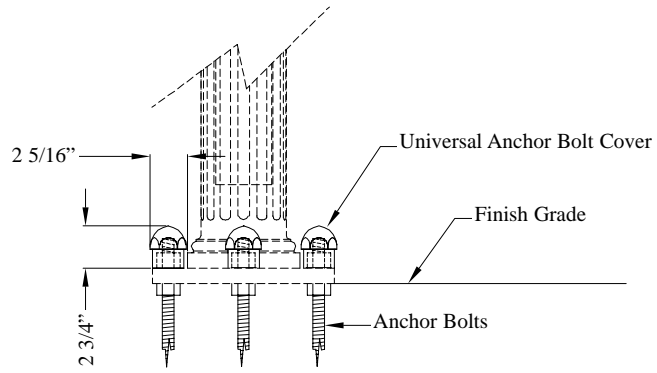

AACUNV  
Cast Aluminum Anchor Bolt Cover  
Universal

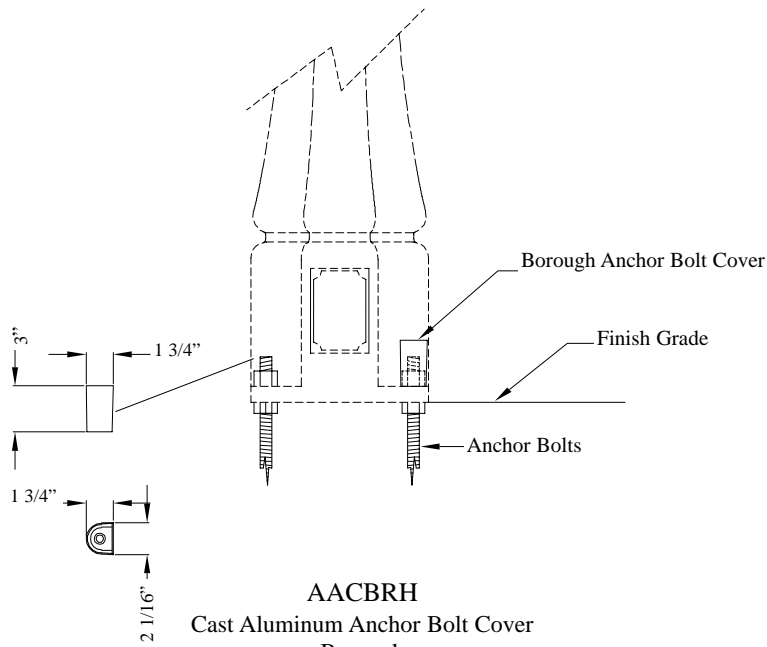

AACBRH  
Cast Aluminum Anchor Bolt Cover  
Borough

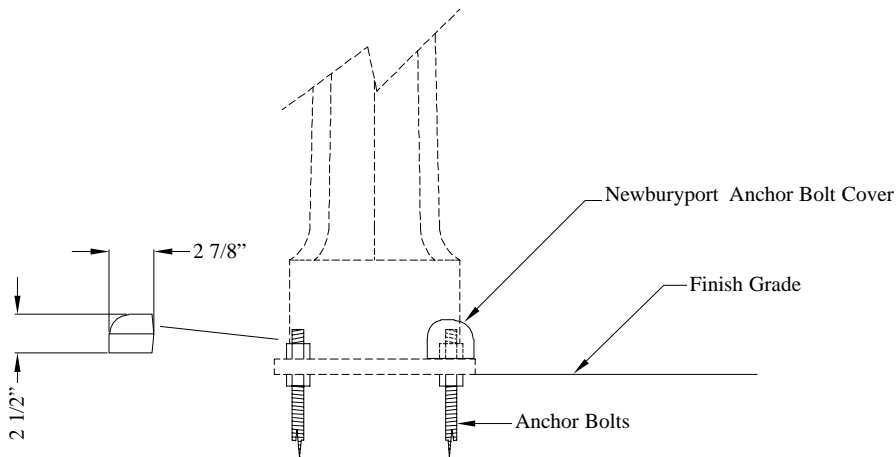

AACNBP  
Cast Aluminum Anchor Bolt Cover  
Newburyport



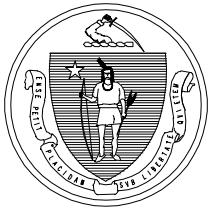

Created for:  
MHD  
City of Mulbury,  
Massachusetts



Created for:  
City of Bridgeport,  
Connecticut

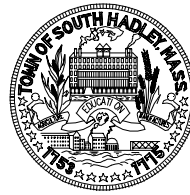

Created for:  
Town of South Hadley,  
Massachusetts



Created for:  
Historic Downtown  
Westerly-Pawcatuck,  
Rhode Island



Created for:  
City of Salem,  
Oregon



Created for:  
Village of Montauk,  
Long Island,  
New York

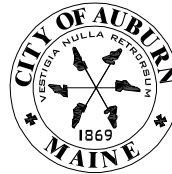

Created for:  
City of Auburn,  
Maine

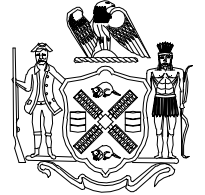

Created for:  
City Hall Park  
New York,  
New York



Created for:  
City of Salem,  
Massachusetts



Created for:  
Athenian Street  
City of Cambridge,  
Massachusetts



Created for:  
City of Englewood,  
Ohio



Created for:  
Town of Medford,  
Massachusetts



Created for:  
Quality Hill Community  
Kansas City,  
Missouri

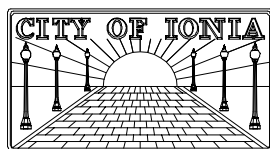

Created for:  
City of Ionia,  
Michigan



Created for:  
Historic Area Wright Dunbar  
City of Dayton,  
Ohio

