

This drawing is the property of Spring City Elect. Mfg. Co. and is issued to the recipient with the understanding that it shall not be copied, duplicated, passed on to unauthorized parties, nor used for any purpose other than that for which it is specifically furnished except with Spring City's written permission.

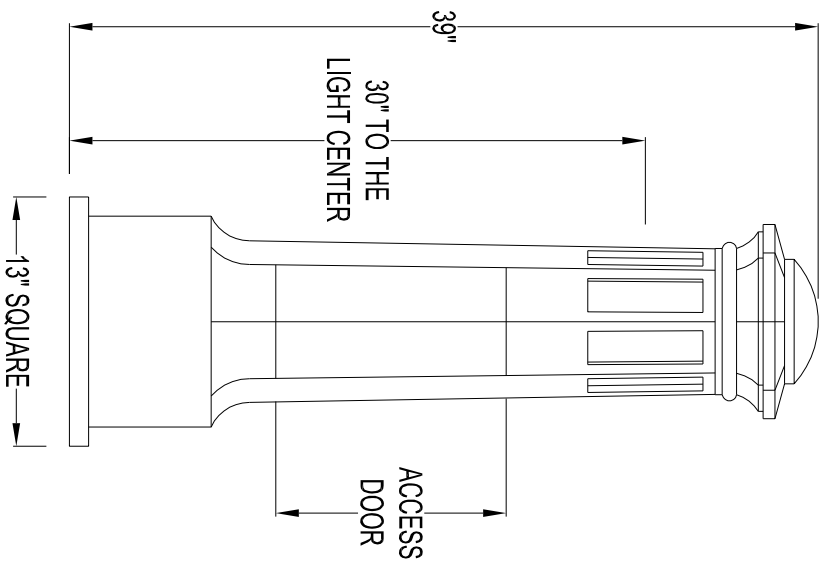

LIGHTED BOLLARD SPECIFICATIONS

- STYLE: NEWBURYPORT
 HEIGHT: 39"
 LIGHT CENTER: 30"
 BASE: 13" SQUARE
 MATERIAL: (A) CAST ALUMINUM ALLOY ANSI 356 PER A.S. T.M. B26-95
 (I) CAST IRON PER A.S. T.M. A48-83 CLASS 30
 (D) CAST DUCTILE IRON PER A536-84 GRADE 65-45-12
 CLEAR ACRYLIC
 PRIME PAINT THEN FINISH SHERWIN WILLIAMS
 ACROLOL - PLEASE ADVISE COLOR
 WATT HPS MH MV INC OTHER _____
 120 208 240 277 480 QUAD
 MEDIUM BASE OTHER _____
 LOCATED IN BASE SECURED WITH TAMPER PROOF HEX
 SOCKET SECURITY MACHINE SCREWS
 SOCKET SECURITY MACHINE SCREWS
 DRILL AND TAP INSIDE WALL OF BASE OPPOSITE ACCESS DOOR TO
 ACCOMMODATE A 1/4"-20 GROUND STUD (GROUND STUD SUPPLIED BY OTHERS)
 (4) 3/4" DIA. X 24" LONG + 3" HOOK (FULLY GALVANIZED WITH
 1 GALVANIZED NUT AND 1 GALVANIZED WASHER PER BOLT)
 3" REQUIRED
 ANCHOR BOLTS:
 BOLT PROJECTION:
 GROUND STUD PROVISIONS:
 ACCESS DOOR:
 SOCKET:
 VOLTAGE:
 LAMPING:
 FINISH:
 CYLINDER:
 FINISH:
 ACCESS DOOR:
 SOCKET:
 VOLTAGE:
 LAMPING:

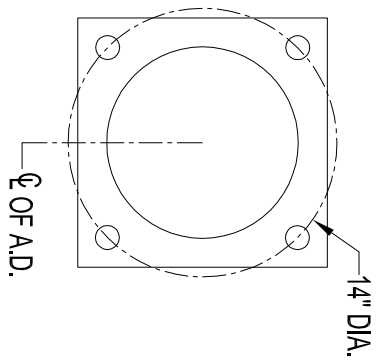

SINCE 1964

Spring City Electrical Mfg. Co.
 HALL AND MAIN STREETS - P.O. BOX 19 - SPRING CITY, PA. 19475
 PHONE (610) 948-4000 FAX (610) 948-5577
 E-mail ADDRESS: sales@springcity.com

| | | |
|-------------|------------------------|-----|
| DESCRIPTION | _BDNBP-13-3.25-LT-YCLO | PDF |
|-------------|------------------------|-----|