

*This drawing is the property of Spring City Elect. Mfg. Co. and is issued to the recipient with the understanding that it shall not be copied, duplicated, passed on to unauthorized parties, nor used for any purpose other than that for which it is specifically furnished except with Spring City's written permission.*

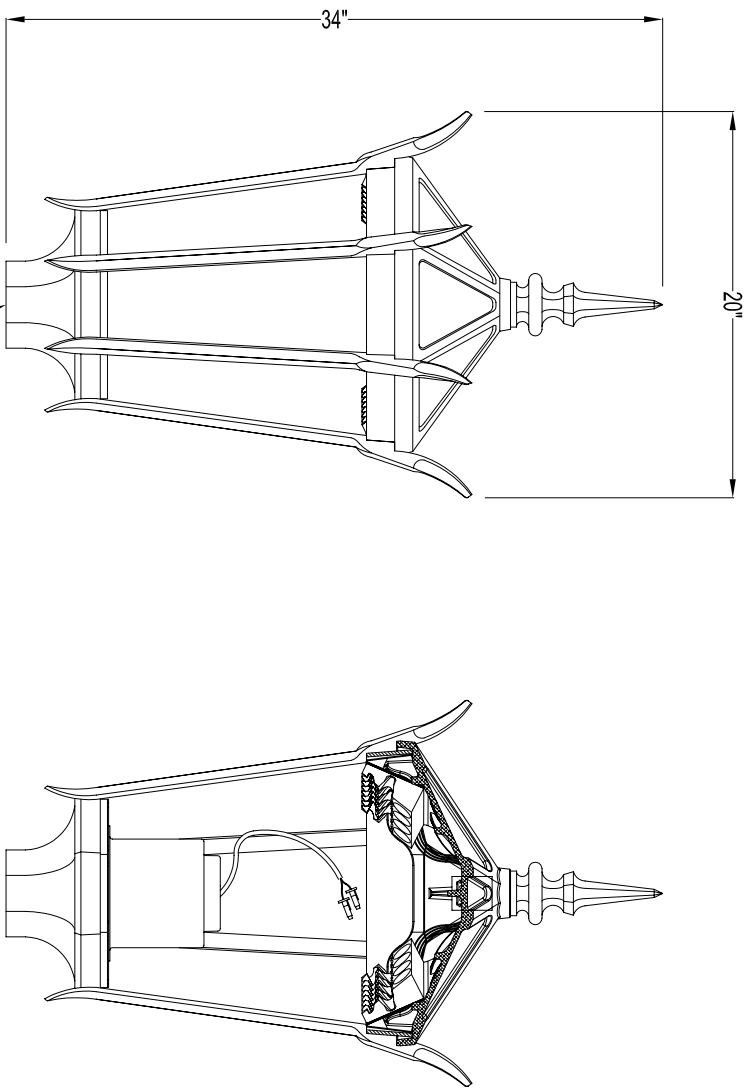

**PROJECTED AREAS AND WEIGHT**

SECTION	PROJ. AREA	Cd	E.P.A.
FIXTURE	2.15 Sq. Ft.	1.20	2.58 Sq. Ft.
TOTAL ASSEMBLY WEIGHT			30 LBS.

**LUMINAIRE SPECIFICATIONS**

STYLE: EDGEWATER (MEDIUM FITTER) WITH COOLCAST™ HEAT DISSIPATING ROOF AND EDGEWATER FINIAL - LED SYSTEM  
 HEIGHT: 34"  
 WIDTH: 20"  
 MATERIAL: CAST ALUMINUM ALLOY ANSI 356 PER A.S.T.M. B26-95  
 LAMPING: GREE MCE AND XPE LED - PLEASE ADVISE WATTAGE (LED \_\_\_) 99 WATT MAX  
 VOLTAGE: ELECTRONIC WIRED AT  (EV1) 120  (EV8) 208  (EV2) 240  (EV7) 277  
 NUMBER OF BOARDS:  (X2) 2-BOARDS  (X5) 5-BOARDS  
 PANELS:  (Y \_\_) ACRYLIC  (PLO) CLEAR  (SDP) SEEDED  (PLF) FROSTED  (P \_\_) POLYCARBONATE  (PLO) CLEAR  (PLF) FROSTED  (PBP) PEBBLED  
 DISTRIBUTION:  (HC2) TYPE II - SILVER REFLECTOR  (HC3) TYPE III - WHITE REFLECTOR  (HC5) TYPE V - NO REFLECTOR  
 FINISH: PRIME PAINT THEN FINISH SHERWIN WILLIAMS ACRYLON - PLEASE ADVISE COLOR  
 COLOR TEMPERATURE:  (WARM) 3000K  (NEUTRAL) 4500K  (COOL) 6000K  
 PHOTO CONTROL:  OPTIONAL - BUTTON TYPE

SINCE 1942  
  
**Spring City Electrical Mfg. Co.**  
 HALL AND MAIN STREETS - P.O. BOX 19 - SPRING CITY, PA. 19475  
 PHONE (610) 948-4000 FAX (610) 948-5577  
 E-mail ADDRESS: sales@springcity.com

DESCRIPTION	ALMEDM-LED __/EV __X __ - ____-HC __-FED	PDF