

*This drawing is the property of Spring City Elect. Mfg. Co. and is issued to the recipient with the understanding that it shall not be copied, duplicated, passed on to unauthorized parties, nor used for any purpose other than that for which it is specifically furnished except with Spring City's written permission.*

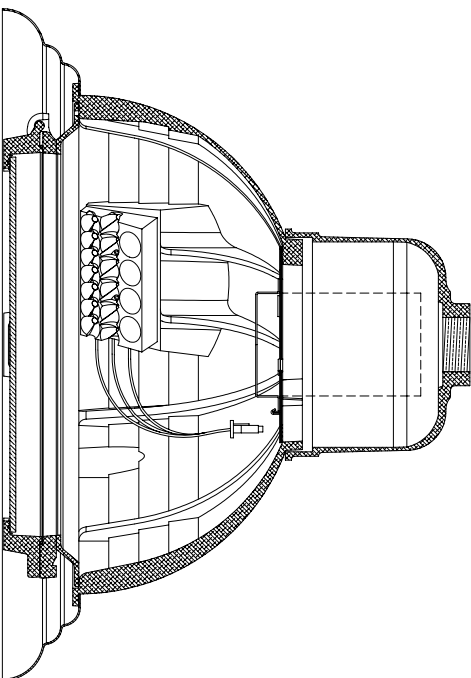
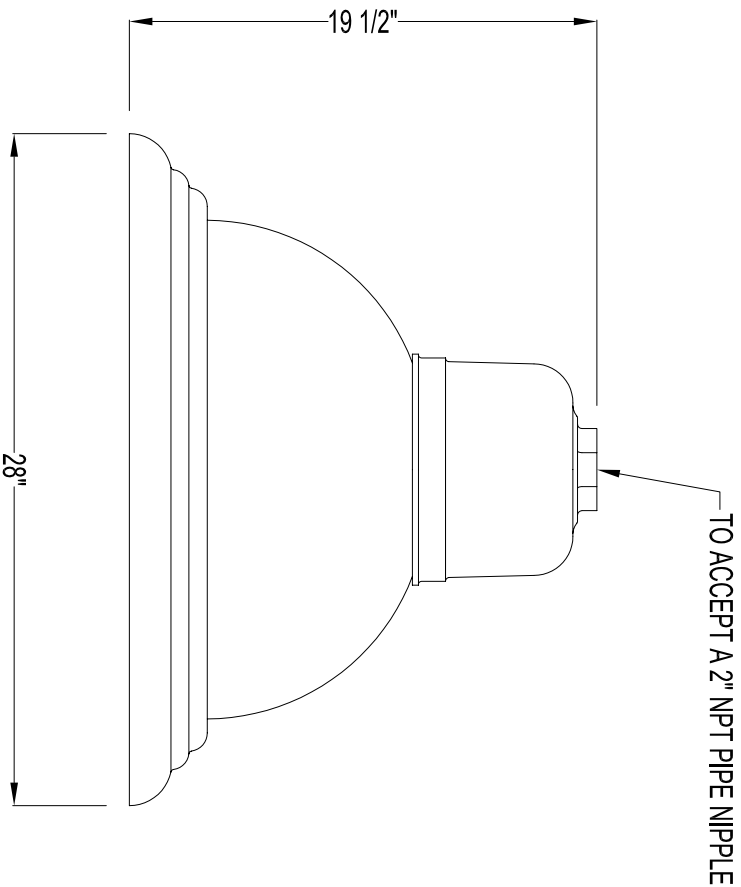

**LUMINAIRE SPECIFICATIONS**

- STYLE: EXTON WITH COOLCAST™ HEAT DISSIPATING HOUSING - LED SYSTEM
- HEIGHT: 19 1/2"
- WIDTH: 28" DIAMETER
- MATERIAL: CAST ALUMINUM ALLOY ANSI 366 PER A.S.T.M. B26-95
- LAMPING: CREE MCE AND XPE LED - PLEASE ADVISE WATTAGE (LE \_\_\_\_\_) 200 WATT MAX
- VOLTAGE: ELECTRONIC WIRED AT  (EV1) 120  (EV8) 208  (EV2) 240  (EV7) 277
- NUMBER OF BOARDS: 2-BOARDS
- PANEL: TEMPERED GLASS - CLEAR
- DISTRIBUTION:  (HC2) TYPE II - SILVER REFLECTOR  (HC3) TYPE III - WHITE REFLECTOR  (HC5) TYPE V - NO REFLECTOR
- FINISH: PRIME PAINT THEN FINISH SHERWIN WILLIAMS ACROLON - PLEASE ADVISE COLOR
- COLOR TEMPERATURE:  (WARM) 3000K  (NEUTRAL) 4500K  (COOL) 6000K
- PHOTO CONTROL:  OPTIONAL - BUTTON TYPE

**PROJECTED AREAS AND WEIGHT**

| SECTION               | PROJ. AREA   | Cd  | E.P.A.       |
|-----------------------|--------------|-----|--------------|
| FIXTURE               | 2.05 Sq. Ft. | 0.5 | 1.02 Sq. Ft. |
| TOTAL ASSEMBLY WEIGHT |              |     | 45 LBS.      |



**Spring City Electrical Mfg. Co.**

SINCE 1967  
 HALL AND MAIN STREETS - P.O. BOX 19 - SPRING CITY, PA. 19475  
 PHONE (610) 948-4000 FAX (610) 948-5577  
 E-mail ADDRESS: sales@springcity.com

| DESCRIPTION | ALMETNLE__EV_X2-GPLO-HC__ | PDF |
|-------------|---------------------------|-----|
|             |                           |     |