

This drawing is the property of Spring City Elect. Mfg. Co. and is issued to the recipient with the understanding that it shall not be copied, duplicated, passed on to unauthorized parties, nor used for any purpose other than that for which it is specifically furnished except with Spring City's written permission.

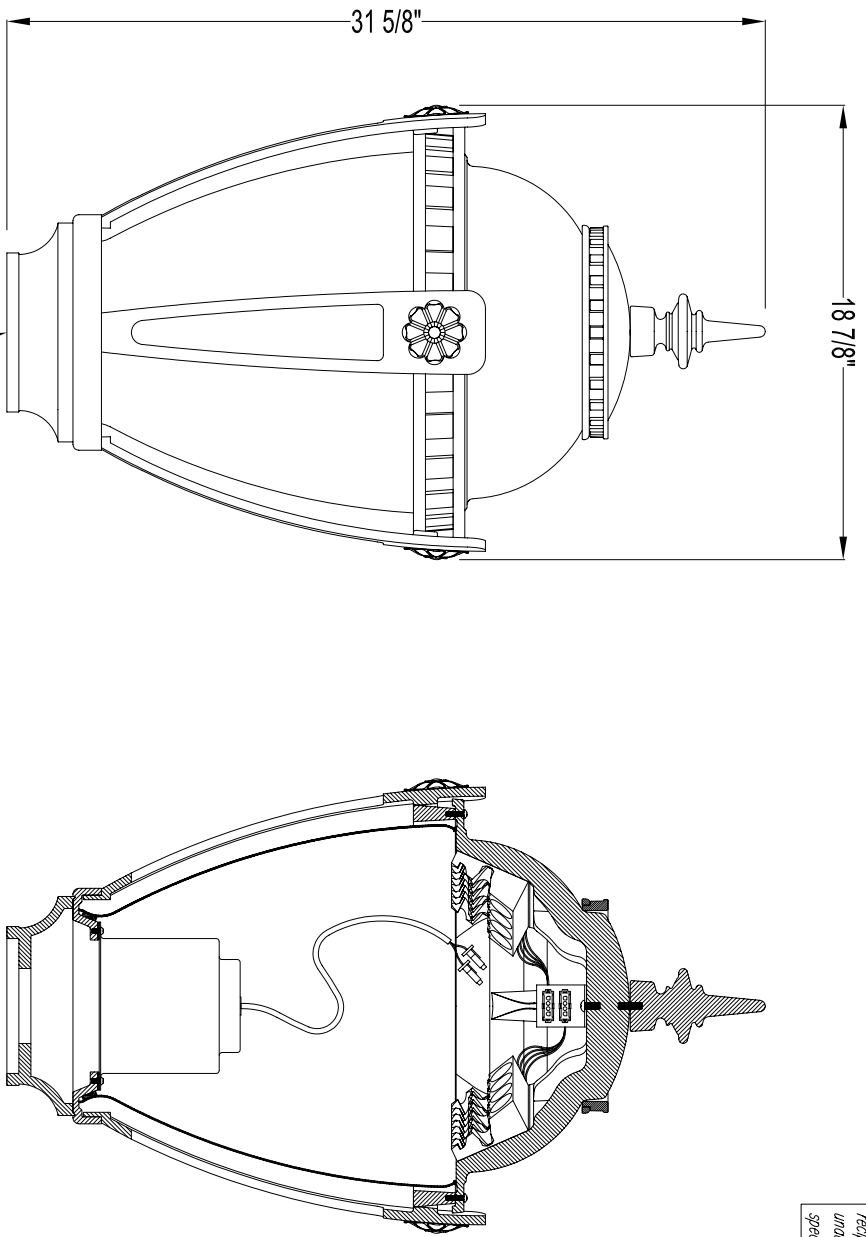

**LUMINAIRE SPECIFICATIONS**

STYLE: FRANKLIN SQUARE WITH COOLCAST™ HEAT DISSIPATING ROOF AND ANAHEIM FINIAL - LED SYSTEM  
 HEIGHT: 31 5/8"  
 WIDTH: 18 7/8"  
 MATERIAL: CAST ALUMINUM ALLOY ANSI 356 PER A.S.T.M. B26-95  
 LAMPING: CREE MCE AND XPE LED - PLEASE ADVISE WATTAGE (LED\_ ) 99 WATT MAX  
 VOLTAGE: ELECTRONIC WIRED AT  (EV1) 120  (EV8) 208  (EV2) 240  (EV7) 277  
 NUMBER OF BOARDS: 2-BOARDS  
 GLOBE:  (YKSF) ACRYLIC KEY SLOTTED FROSTED  (YS19) ACRYLIC STIPPLED 199  
 DISTRIBUTION:  (HC2) TYPE II - SILVER REFLECTOR  (HC3) TYPE III - WHITE REFLECTOR  (HC5) TYPE V - NO REFLECTOR  
 FINISH: PRIME PAINT THEN FINISH SHERWIN WILLIAMS ACROLON - PLEASE ADVISE COLOR  
 COLOR TEMPERATURE:  (WARM) 3000K  (NEUTRAL) 4500K  (COOL) 6000K  
 PHOTO CONTROL:  OPTIONAL - BUTTON TYPE

TO ACCEPT A 2 7/8" DIA. X 2 1/2" HIGH TENON

**PROJECTED AREAS AND WEIGHT**

SECTION	PROJ. AREA	Cd	E.P.A.
FIXTURE	2.09 Sq. Ft.	1.20	2.51 Sq. Ft.
TOTAL ASSEMBLY WEIGHT			42 LBS.



1525 1647  
 HALL AND MAIN STREETS - P.O. BOX 19 - SPRING CITY, PA. 19475  
 PHONE (610) 948-4000 FAX (610) 948-5577  
 E-mail ADDRESS: sales@springcity.com

DESCRIPTION	ALMFKS-LED_ _EV_ X2-Y_ _ _ _ _-HC_ -FAC-CT	PDF