

This drawing is the property of Spring City Elect. Mfg. Co. and is issued to the recipient with the understanding that it shall not be copied, duplicated, passed on to unauthorized parties, nor used for any purpose other than that for which it is specifically furnished except with Spring City's written permission.

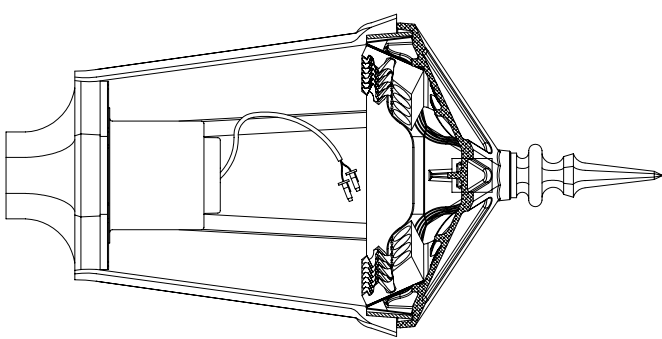
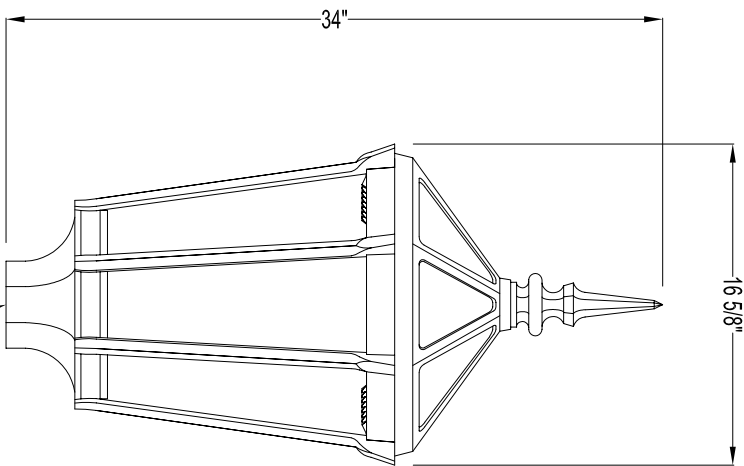

TO ACCEPT A 3 1/2" DIA. X 3" HIGH TENON

PROJECTED AREAS AND WEIGHT

SECTION	PROJ. AREA	Cd	E.P.A.
FIXTURE	2.15 Sq. Ft.	1.20	2.58 Sq. Ft.
TOTAL ASSEMBLY WEIGHT			30 LBS.

LUMINAIRE SPECIFICATIONS

STYLE: WILLIAM AND MARY (MEDIUM FITTER) WITH COOLCAST™ HEAT DISSIPATING ROOF AND EDGEWATER FINIAL - LED SYSTEM
 HEIGHT: 34"
 WIDTH: 16 5/8"
 MATERIAL: CAST ALUMINUM ALLOY ANSI 356 PER A.S.T.M. B26-95
 LAMPING: CREE MCE AND XPE LED - PLEASE ADVISE WATTAGE (LED _____) 99 WATT MAX
 VOLTAGE: ELECTRONIC WIRED AT (EV1) 120 (EV8) 208 (EV2) 240 (EV7) 277
 NUMBER OF BOARDS: (X2) 2-BOARDS (X5) 5-BOARDS
 PANELS: (Y) ACRYLIC (PL0) CLEAR (SDP) SEEDED (PLF) FROSTED
 (P) POLYCARBONATE (PL0) CLEAR (PLF) FROSTED (PBP) PEBBLED
 DISTRIBUTION: (HC2) TYPE II - SILVER REFLECTOR (HC3) TYPE III - WHITE REFLECTOR (HC5) TYPE V - NO REFLECTOR
 FINISH: PRIME PAINT THEN FINISH SHERWIN WILLIAMS ACRYLON - PLEASE ADVISE COLOR
 COLOR TEMPERATURE: (WARM) 3000K (NEUTRAL) 4500K (COOL) 6000K
 PHOTO CONTROL: OPTIONAL - BUTTON TYPE



SINCE 1941
 HALL AND MAIN STREETS - P.O. BOX 19 - SPRING CITY, PA. 19475
 PHONE (610) 948-4000 FAX (610) 948-5577
 E-mail ADDRESS: sales@springcity.com

DESCRIPTION	ALMWMML-LED__EV_X_-_____-HC_-FED	PDF
-------------	----------------------------------	-----