

This drawing is the property of Spring City Elect. Mfg. Co. and is issued to the recipient with the understanding that it shall not be copied, duplicated, passed on to unauthorized parties, nor used for any purpose other than that for which it is specifically furnished except with Spring City's written permission.

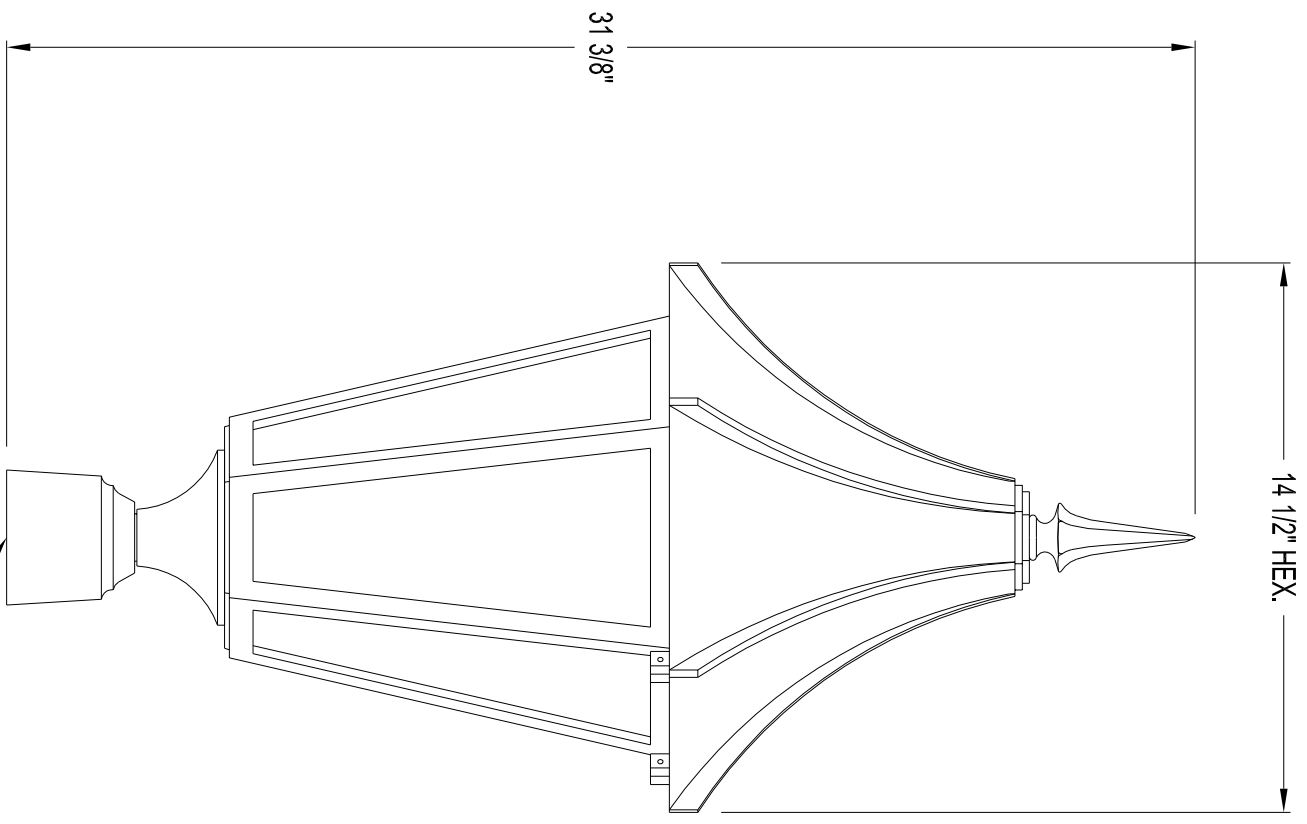

LUMINAIRE SPECIFICATIONS

- STYLE: ASHLAND WITH ATHENS FINIAL
- HEIGHT: 31 3/8"
- WIDTH: 14 1/2" HEXAGONAL
- MATERIAL: CAST ALUMINUM ALLOY ANSI 356 PER A.S.T.M. B26-95
- PANELS: POLYCARBONATE (PLO) CLEAR (WHP) WHITE OTHER _____
- FINISH: PRIME PAINT THEN FINISH SHERWIN WILLIAMS ACROLOX - PLEASE ADVISE COLOR _____
- LAMPING: _____ WATT (150 MAX) INC. OTHER _____
- VOLTAGE: 120 208 240 277 480 QUAD _____
- SOCKET: MEDIUM BASE MOGUL BASE OTHER _____
- PHOTO CONTROL: OPTIONAL - BUTTON TYPE _____
- NOTE: H.I.D. LAMPING REQUIRES REMOTELY MOUNTED BALLAST

TO ACCEPT A 2 7/8" DIA. X 2" HIGH TENON



Spring City Electrical Mfg. Co.

SINCE 1943
 HALL AND MAIN STREETS - P.O. BOX 19 - SPRING CITY, PA. 19475
 PHONE (610) 948-4000 FAX (610) 948-5577
 E-mail ADDRESS: sales@springcity.com

DESCRIPTION	ALMASH-P__-FAT	PDF
-------------	----------------	-----