

*This drawing is the property of Spring City Elect. Mfg. Co. and is issued to the recipient with the understanding that it shall not be copied, duplicated, passed on to unauthorized parties, nor used for any purpose other than that for which it is specifically furnished except with Spring City's written permission.*

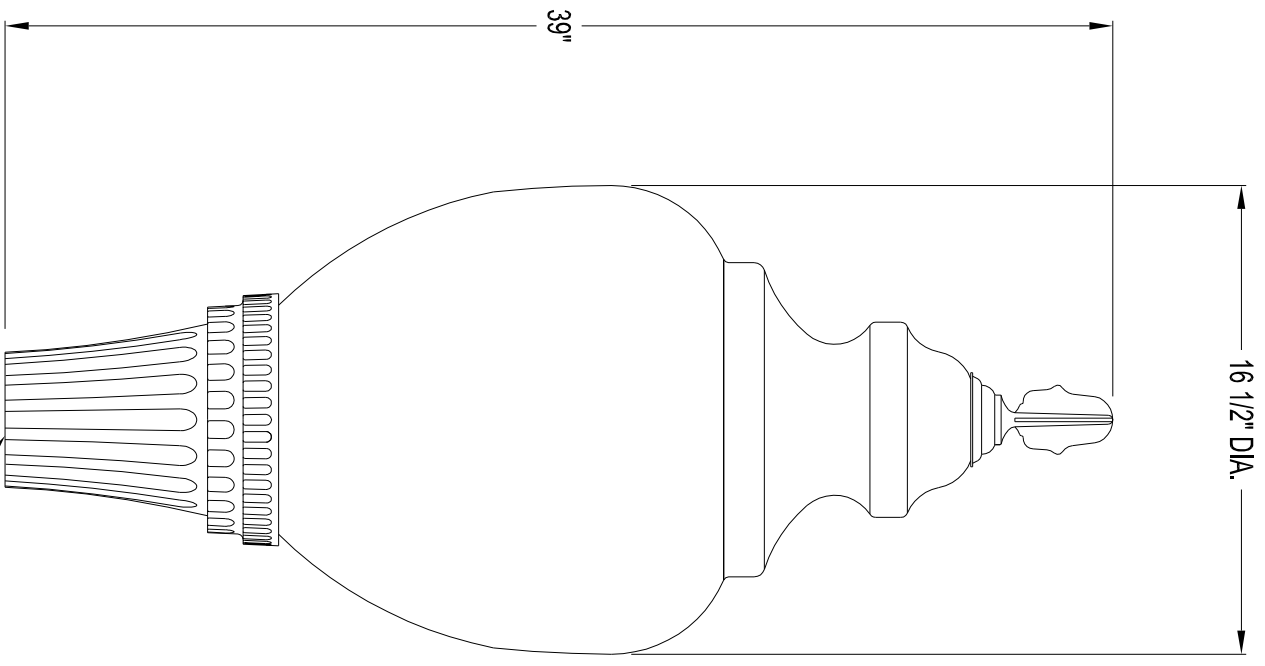

TO ACCEPT A 2 7/8" DIA. X 3" HIGH TENON

**LUMINAIRE SPECIFICATIONS**

**STYLE:** BRENTWOOD CASING - 118 GLOBE WITH FINIAL  
**HEIGHT:** 39"  
**WIDTH:** 16 1/2" DIAMETER  
**MATERIAL:** CAST ALUMINUM ALLOY ANSI 356 PER A.S.T.M. B26-95  
**GLOBE:** STIPPLED POLYCARBONATE  
**FINISH:** PRIME PAINT THEN FINISH SHERWIN WILLIAMS ACRYLON - PLEASE ADVISE COLOR  
**LAMPING:** WATT  HPS  MH  MV  JINC  OTHER \_\_\_\_\_  
**VOLTAGE:**  120  208  240  277  480  QUAD  
**SOCKET:**  MEDIUM BASE  MOGUL BASE  OTHER \_\_\_\_\_  
**PHOTO CONTROL:** OPTIONAL - BUTTON TYPE



SINCE 1843  
 HALL AND MAIN STREETS - P.O. BOX 19 - SPRING CITY, PA. 19475  
 PHONE (610) 948-4000 FAX (610) 948-5577  
 E-mail ADDRESS: sales@springcity.com

DESCRIPTION	ALMBRT-PS11-FPP	PDF
-------------	-----------------	-----