

16" DIA.

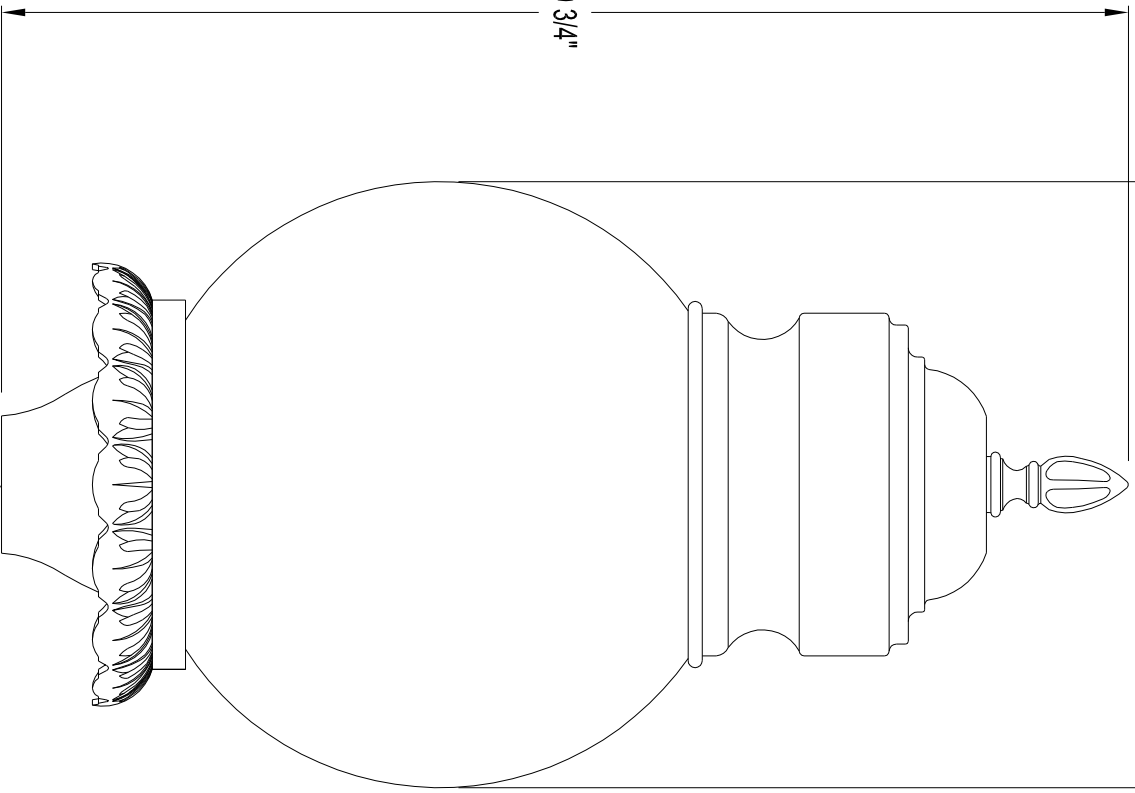

29 3/4"

TO ACCEPT A 2 7/8" DIA. X 1 1/2" HIGH TENON

LUMINAIRE SPECIFICATIONS

- STYLE: CHARLESTON MEDIUM CASING - 16" BALL GLOBE READING SPUN TOP AND BOROUGH FINIAL
- HEIGHT: 29 3/4"
- WIDTH: 16" DIAMETER
- MATERIAL: (A) CAST ALUMINUM ALLOY ANSI 356 PER A.S.T.M. B26-95 AND SPUN ALUMINUM
 (I) CAST IRON PER A.S.T.M. A48-83 CLASS 30 AND SPUN ALUMINUM
- GLOBE: WHITE POLYCARBONATE
- FINISH: PRIME PAINT THEN FINISH SHERWIN WILLIAMS ACROLON - PLEASE ADVISE COLOR
- LAMPING: WATT HPS MH MV INC OTHER _____
- VOLTAGE: 120 208 240 277 480 QUAD
- SOCKET: MEDIUM BASE MOGUL BASE OTHER _____
- PHOTO CONTROL: OPTIONAL - BUTTON TYPE

This drawing is the property of Spring City Elect. Mfg. Co. and is issued to the recipient with the understanding that it shall not be copied, duplicated, passed on to unauthorized parties, nor used for any purpose other than that for which it is specifically furnished except with Spring City's written permission.



SINCE 1843
HALL AND MAIN STREETS - P.O. BOX 19 - SPRING CITY, PA. 19475
PHONE (610) 948-4000 FAX (610) 948-5577
E-mail ADDRESS: sales@springcity.com

DESCRIPTION	_LMCHM-PW16-FBR-RS	PDF
-------------	--------------------	-----