

*This drawing is the property of Spring City Elect. Mfg. Co. and is issued to the recipient with the understanding that it shall not be copied, duplicated, passed on to unauthorized parties, nor used for any purpose other than that for which it is specifically furnished except with Spring City's written permission.*

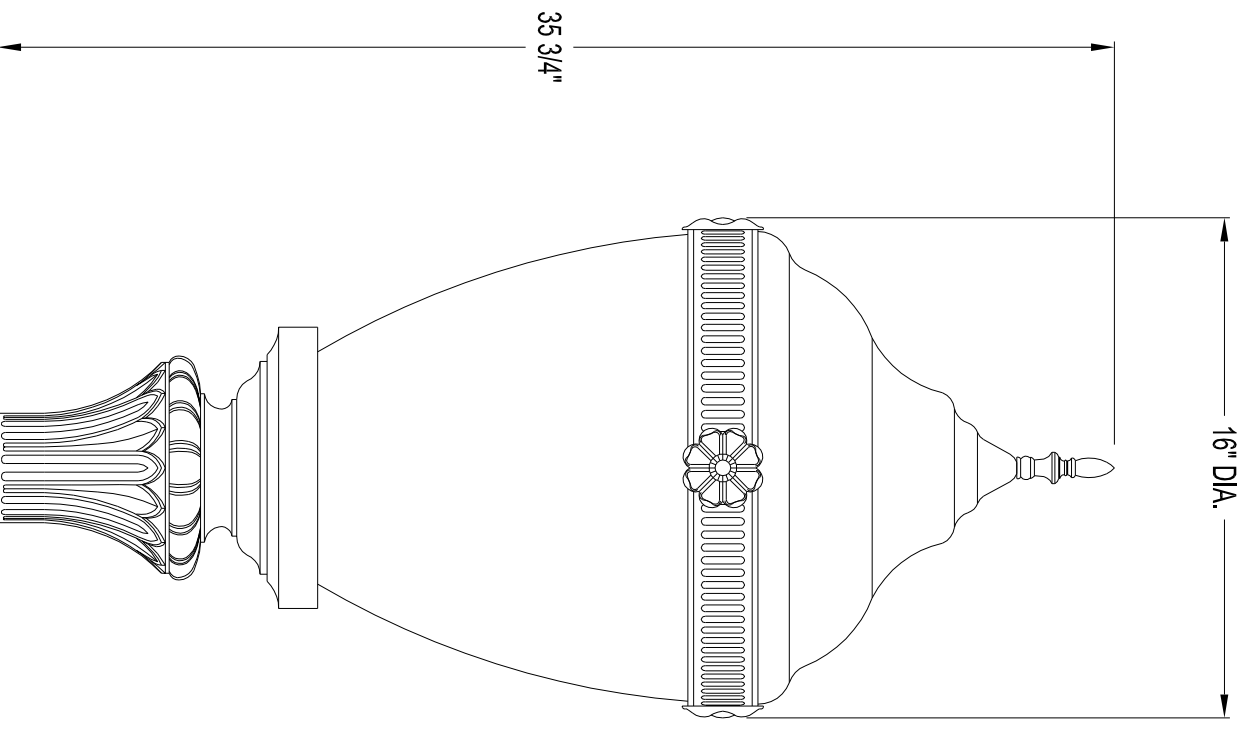

TO ACCEPT A 2 7/8" O.D. x 2 1/2" HIGH TENON

**LUMINAIRE SPECIFICATIONS**

STYLE: FOURTEEN "N" CASING - 199 GLOBE WITH BRASS BAND AND FINIAL  
 HEIGHT: 35 3/4"  
 WIDTH: 16" DIAMETER  
 MATERIAL:  (A) CAST ALUMINUM ALLOY ANSI 356 PER A.S.T.M. B26-95  
 (I) CAST IRON PER A.S.T.M. A48-83 CLASS 30  
 GLOBE: STIPPLED POLYCARBONATE  
 FINISH: PRIME PAINT THEN FINISH SHERWIN WILLIAMS ACROLOX - PLEASE ADVISE COLOR  
 LAMPING: WATT  HPS  MH  MV  INC  OTHER \_\_\_\_\_  
 VOLTAGE:  120  208  240  277  480  QUAD  
 SOCKET:  MEDIUM BASE  MOGUL BASE  OTHER \_\_\_\_\_  
 PHOTO CONTROL: \_\_\_\_\_  
 OPTIONAL - BUTTON TYPE \_\_\_\_\_



SINCE 1883  
 HALL AND MAIN STREETS - P.O. BOX 19 - SPRING CITY, PA. 19475  
 PHONE (610) 948-4000 FAX (610) 948-5577  
 E-mail ADDRESS: sales@springcity.com

DESCRIPTION	_LMFTN-PS19-FSB-BH	PDF
-------------	--------------------	-----