

This drawing is the property of Spring City Elect. Mfg. Co. and is issued to the recipient with the understanding that it shall not be copied, duplicated, passed on to unauthorized parties, nor used for any purpose other than that for which it is specifically furnished except with Spring City's written permission.

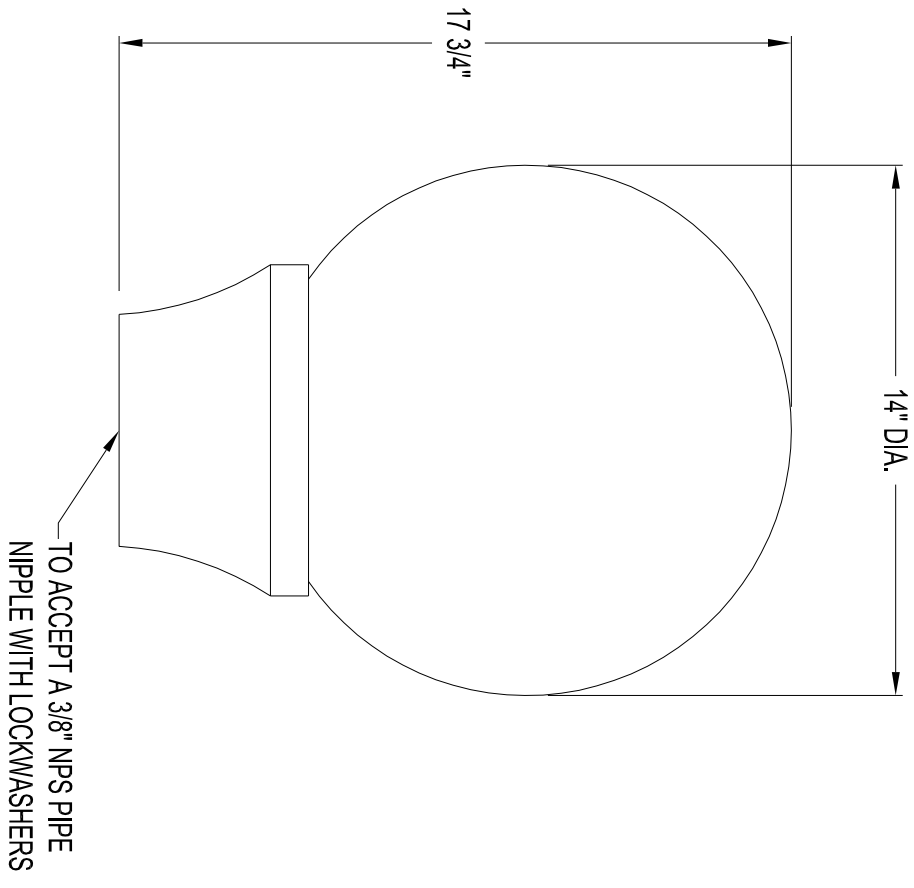

LUMINAIRE SPECIFICATIONS

STYLE: MARINER CASING - 14" BALL GLOBE
HEIGHT: 17 3/4"
WIDTH: 14" DIAMETER
MATERIAL: CAST ALUMINUM ALLOY ANSI 356 PER A.S.T.M. B26-95
GLOBE: WHITE POLYCARBONATE
FINISH: PRIME PAINT THEN FINISH SHERWIN WILLIAMS ACRYLON - PLEASE ADVISE COLOR
LAMPING: WATT HPS MH MV INC OTHER _____
VOLTAGE: 120 208 240 277 480 QUAD
SOCKET: MEDIUM BASE MOGUL BASE OTHER _____
PHOTO CONTROL: _____ **OPTIONAL - BUTTON TYPE**

Spring City Electrical Mfg. Co.

HALL AND MAIN STREETS - P.O. BOX 19 - SPRING CITY, PA. 19475
 PHONE (610) 948-4000 FAX (610) 948-5577
 E-mail ADDRESS: sales@springcity.com

DESCRIPTION	ALMMRN-PS14	PDF
-------------	-------------	-----