

This drawing is the property of Spring City Elect. Mfg. Co. and is issued to the recipient with the understanding that it shall not be copied, duplicated, passed on to unauthorized parties, nor used for any purpose other than that for which it is specifically furnished except with Spring City's written permission.

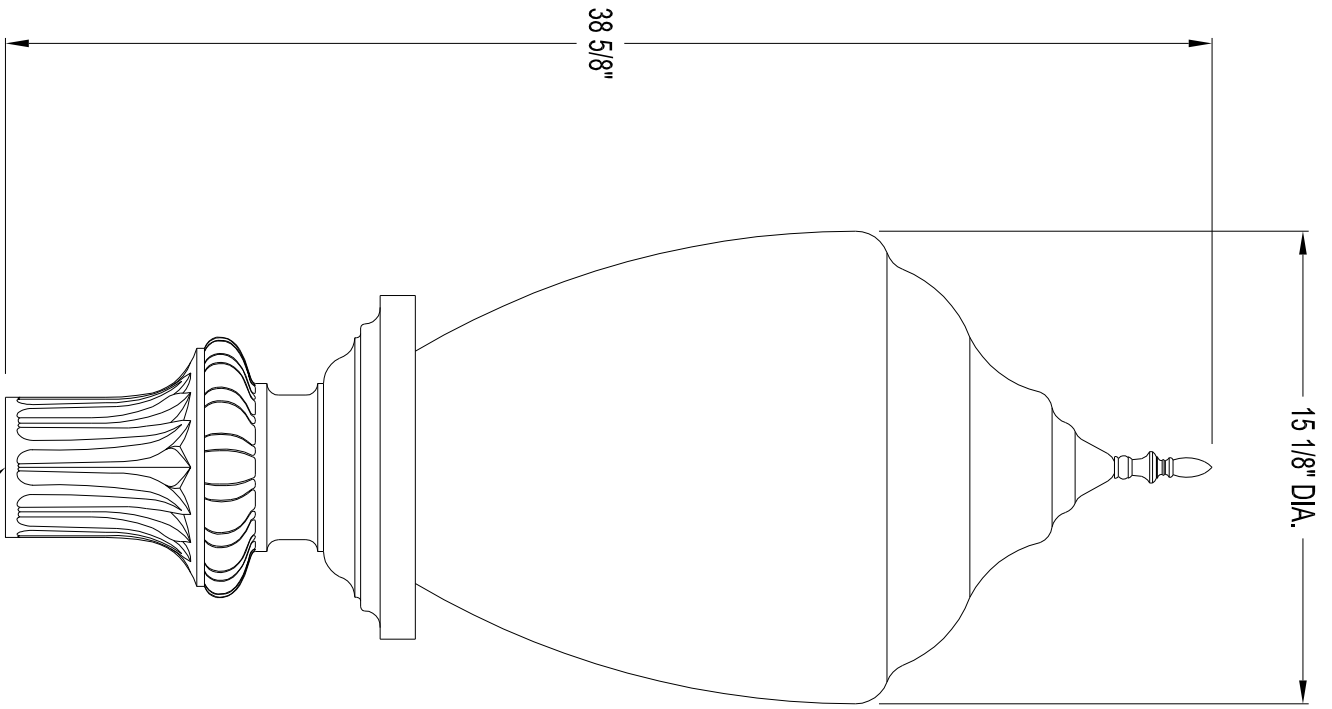

LUMINAIRE SPECIFICATIONS

STYLE: WASHINGTON CASING - 199 GLOBE WITH FINIAL
 HEIGHT: 38 5/8"
 WIDTH: 15 1/8" DIAMETER
 MATERIAL: (A) CAST ALUMINUM ALLOY ANSI 356 PER A.S.T.M. B26-95
 (I) CAST IRON PER A.S.T.M. A48-83 CLASS 30
 GLOBE: STIPPLED POLYCARBONATE
 FINISH: PRIME PAINT THEN FINISH SHERWIN WILLIAMS ACRYLON - PLEASE ADVISE COLOR
 LAMPING: WATT HPS MH MV INC OTHER _____
 VOLTAGE: 120 208 240 277 480 QUAD
 SOCKET: MEDIUM BASE MOGUL BASE OTHER _____
 PHOTO CONTROL: _____
 OPTIONAL - BUTTON TYPE _____

TO ACCEPT A 3 1/2" DIA. X 3" HIGH TENON

Spring City Electrical Mfg. Co.
SINCE 1843
 HALL AND MAIN STREETS - P.O. BOX 19 - SPRING CITY, PA. 19475
 PHONE (610) 948-4000 FAX (610) 948-5577
 E-mail ADDRESS: sales@springcity.com

DESCRIPTION	_LMWSSHPS19-FPP	PDF
-------------	-----------------	-----